

Lecture 5: DC motors

Instructor:

M.S. Syed Ajmal



Preliminary notes

DC power systems are not very common in the contemporary engineering practice. However, DC motors still have many practical applications, such as automobile, aircraft, and portable electronics, in speed control applications...

An advantage of DC motors is that it is easy to control their speed in a wide diapason.

DC generators are quite rare.

Most DC machines are similar to AC machines: i.e. they have AC voltages and current within them. DC machines have DC outputs just because they have a mechanism converting AC voltages to DC voltages at their terminals. This mechanism is called a commutator; therefore, DC machines are also called commutating machines.



The simplest DC machine

The simplest DC rotating machine consists of a single loop of wire rotating about a fixed axis. The magnetic field is supplied by the North and South poles of the magnet.

Rotor is the rotating part;
Stator is the stationary part.

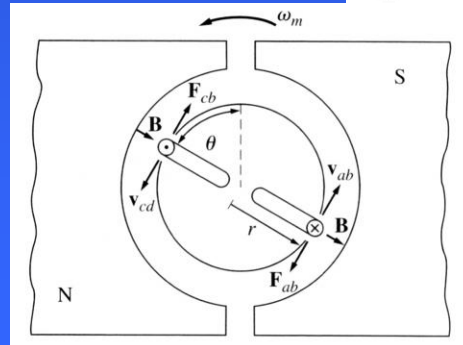
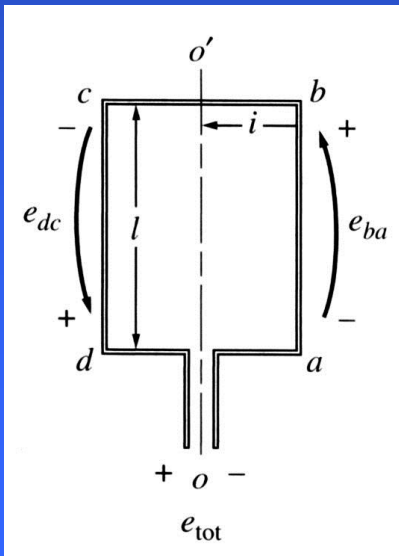
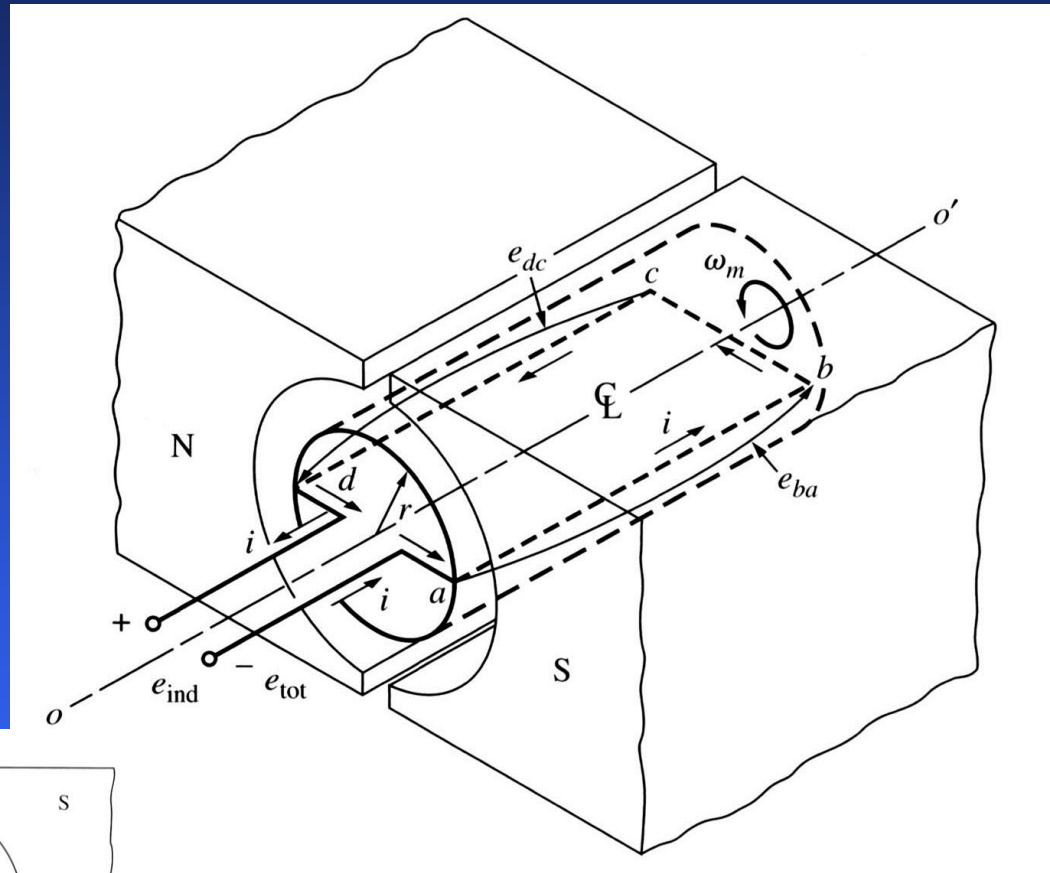

The simplest DC machine

We notice that the rotor lies in a slot curved in a ferromagnetic stator core, which, together with the rotor core, provides a constant-width air gap between the rotor and stator.

The reluctance of air is much larger than the reluctance of core. Therefore, the magnetic flux must take the shortest path through the air gap.

As a consequence, the magnetic flux is perpendicular to the rotor surface everywhere under the pole faces.

Since the air gap is uniform, the reluctance is constant everywhere under the pole faces. Therefore, magnetic flux density is also constant everywhere under the pole faces.

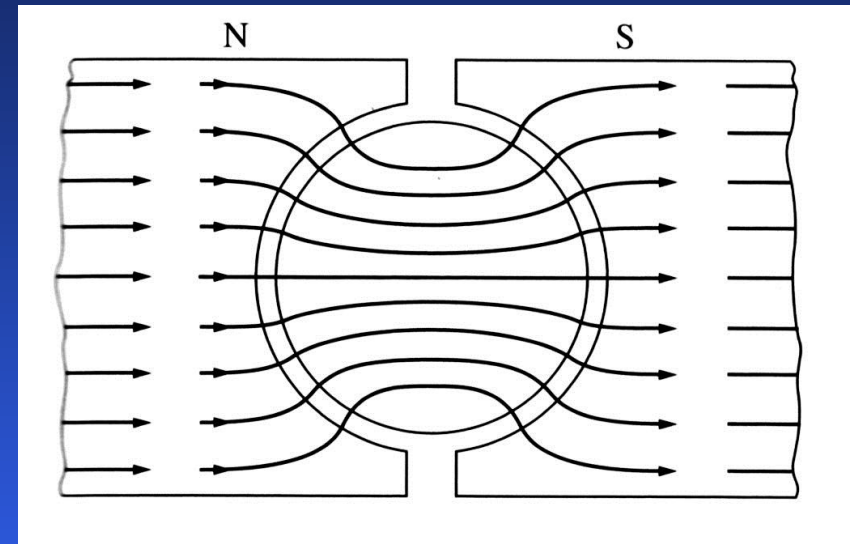

The simplest DC machine

1. Voltage induced in a rotating loop

If a rotor of a DC machine is rotated, a voltage will be induced...

The loop shown has sides ab and cd perpendicular to the figure plane, bc and da are parallel to it.

The total voltage will be a sum of voltages induced on each segment of the loop.

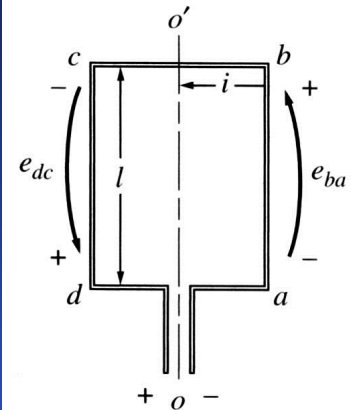

Voltage on each segment is:

$$e_{ind} = (\mathbf{v} \times \mathbf{B}) \cdot \mathbf{l} \quad (5.5.1)$$

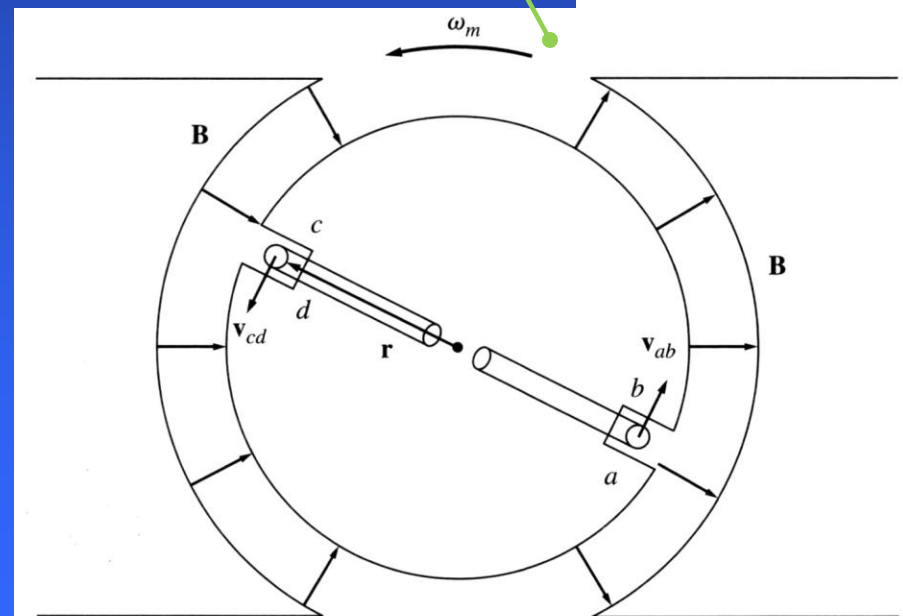

The simplest DC machine

1) *ab*: In this segment, the velocity of the wire is tangential to the path of rotation. Under the pole face, velocity v is perpendicular to the magnetic field B , and the vector product $v \times B$ points into the page. Therefore, the voltage is

$$e_{ba} = (\mathbf{v} \times \mathbf{B}) \cdot \mathbf{l} = \begin{cases} vBl & \text{– into page – under the pole face} \\ 0 & \text{– beyond the pole edges} \end{cases} \quad (5.6.1)$$

2) *bc*: In this segment, vector product $v \times B$ is perpendicular to l . Therefore, the voltage is zero.

3) *cd*: In this segment, the velocity of the wire is tangential to the path of rotation. Under the pole face, velocity v is perpendicular to the magnetic flux density B , and the vector product $v \times B$ points out of the page. Therefore, the voltage is

$$e_{dc} = (\mathbf{v} \times \mathbf{B}) \cdot \mathbf{l} = \begin{cases} vBl & \text{– out of page – under the pole face} \\ 0 & \text{– beyond the pole edges} \end{cases} \quad (5.6.2)$$

4) *da*: In this segment, vector product $v \times B$ is perpendicular to l . Therefore, the voltage is zero.



The simplest DC machine

The total induced voltage on the loop is:

$$e_{tot} = e_{ba} + e_{cb} + e_{dc} + e_{ad} \quad (5.7.1)$$

$$e_{tot} = \begin{cases} 2vBl & \text{under the pole faces} \\ 0 & \text{beyond the pole edges} \end{cases} \quad (5.7.2)$$

When the loop rotates through 180° , segment ab is under the north pole face instead of the south pole face. Therefore, the direction of the voltage on the segment reverses but its magnitude remains constant, leading to the total induced voltage to be \rightarrow

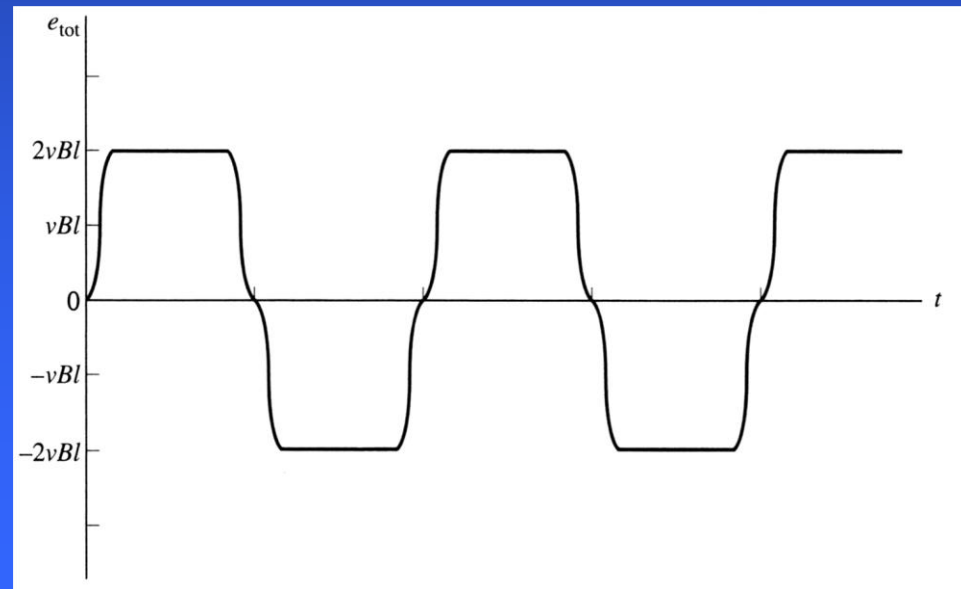

The simplest DC machine

The tangential velocity of the loop's edges is

$$v = r\omega \quad (5.8.1)$$

where r is the radius from the axis of rotation to the edge of the loop. The total induced voltage:

$$e_{tot} = \begin{cases} 2r\omega Bl & \text{under the pole faces} \\ 0 & \text{beyond the pole edges} \end{cases} \quad (5.8.2)$$

The rotor is a cylinder with surface area $2\pi rl$. Since there are two poles, the area of the rotor under each pole is $A_p = \pi rl$. Therefore:

$$e_{tot} = \begin{cases} \frac{2}{\pi} A_p B \omega & \text{under the pole faces} \\ 0 & \text{beyond the pole edges} \end{cases} \quad (5.8.3)$$

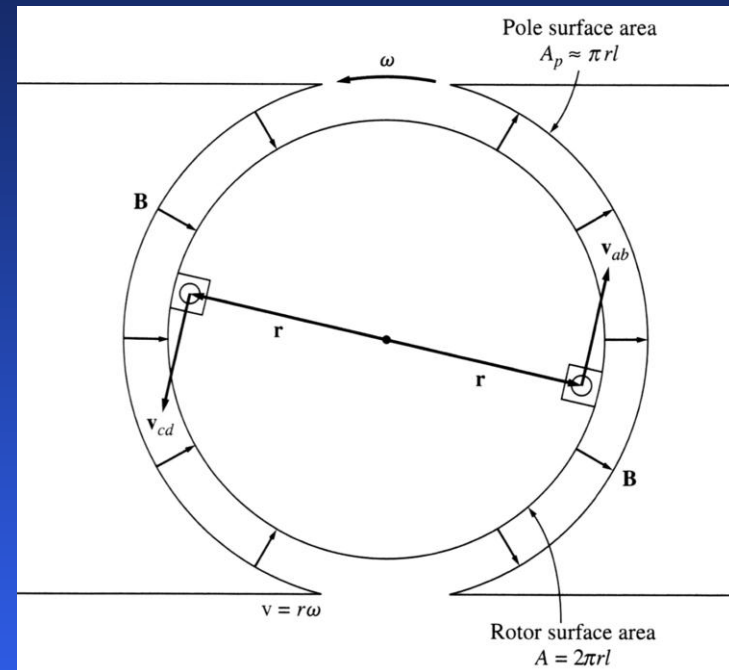

The simplest DC machine

Assuming that the flux density B is constant everywhere in the air gap under the pole faces, the total flux under each pole is

$$\phi = A_p B \quad (5.9.1)$$

The total voltage is

$$e_{tot} = \begin{cases} \frac{2}{\pi} \phi \omega & \text{under the pole faces} \\ 0 & \text{beyond the pole edges} \end{cases} \quad (5.9.2)$$

The voltage generated in any real machine depends on the following factors:

1. The flux inside the machine;
2. The rotation speed of the machine;
3. A constant representing the construction of the machine.



The simplest DC machine

2. Getting DC voltage out of a rotating loop

A voltage out of the loop is alternatively a constant positive value and a constant negative value.

One possible way to convert an alternating voltage to a constant voltage is by adding a commutator segment/brush circuitry to the end of the loop. Every time the voltage of the loop switches direction, contacts switch connection.

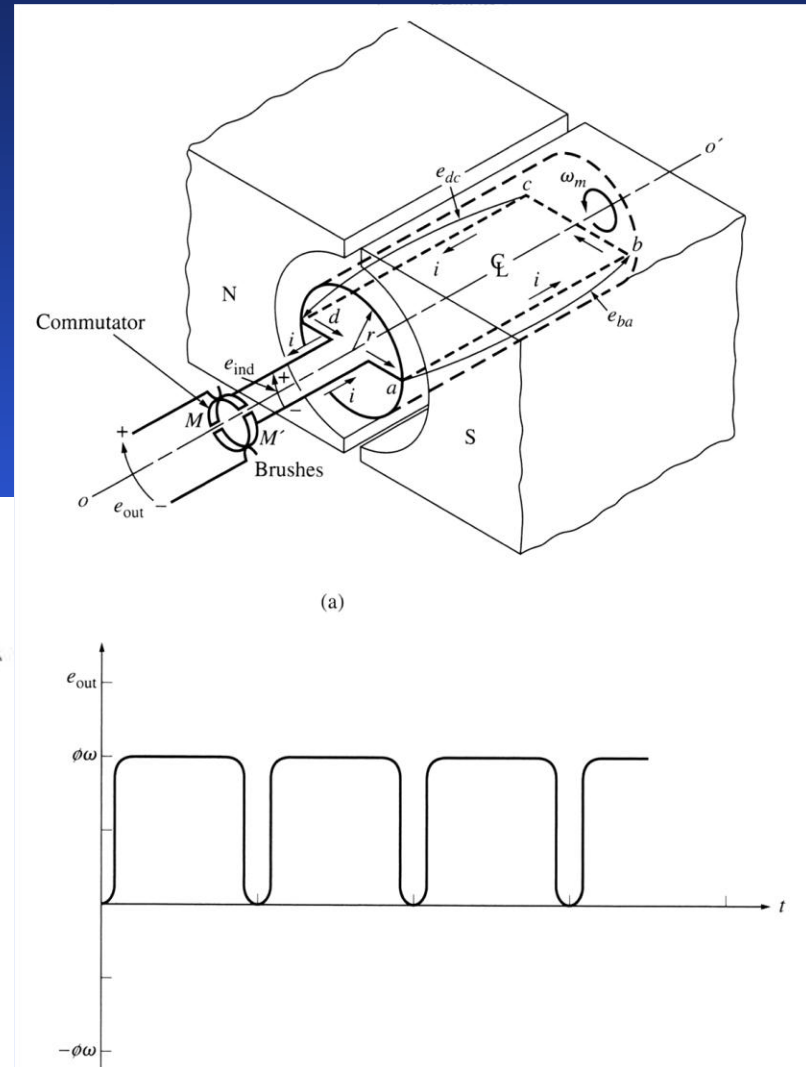
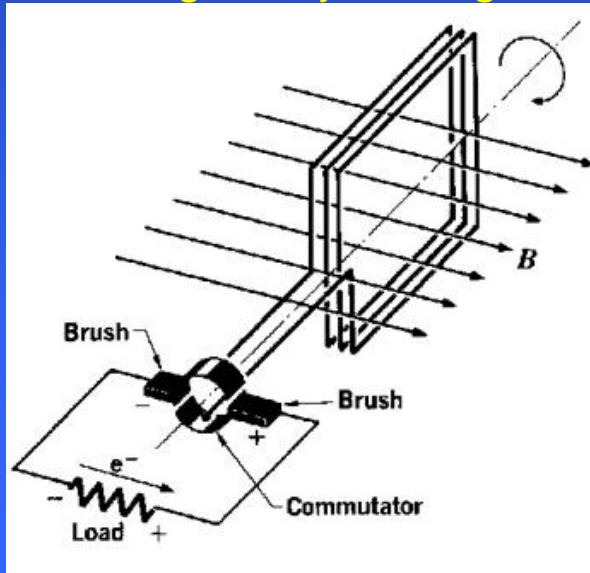

The simplest DC machine

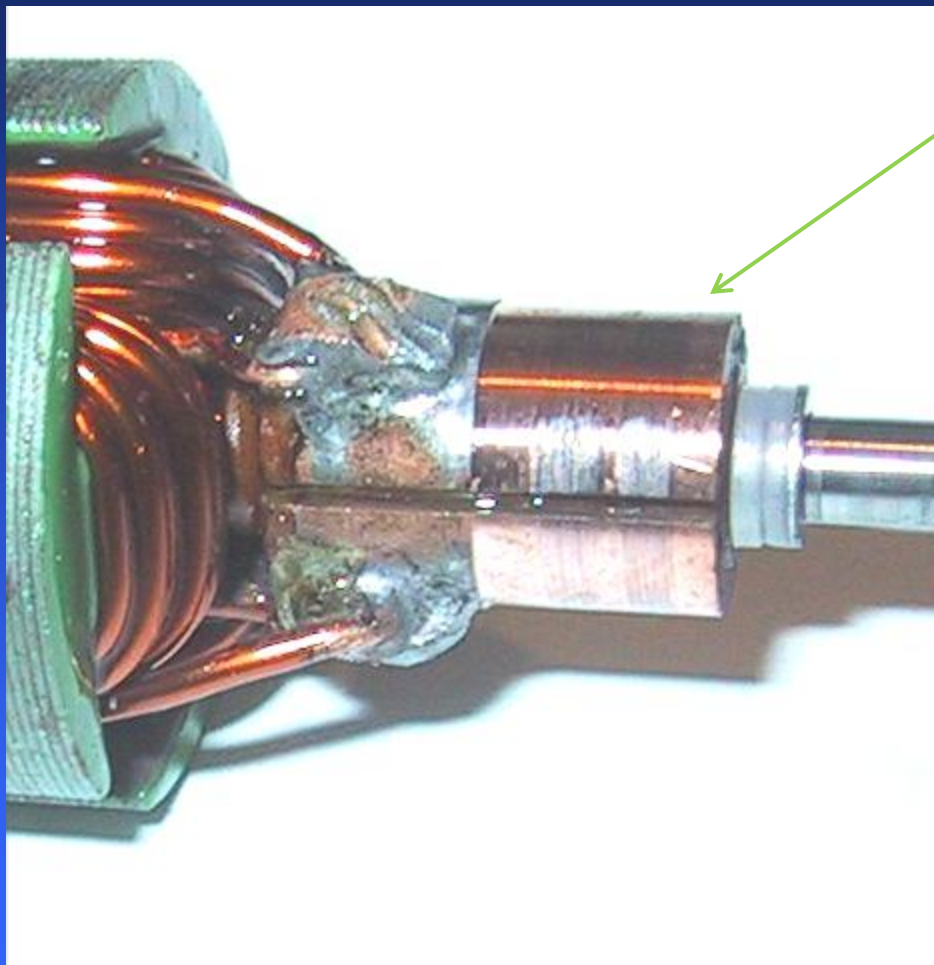

segments

brushes

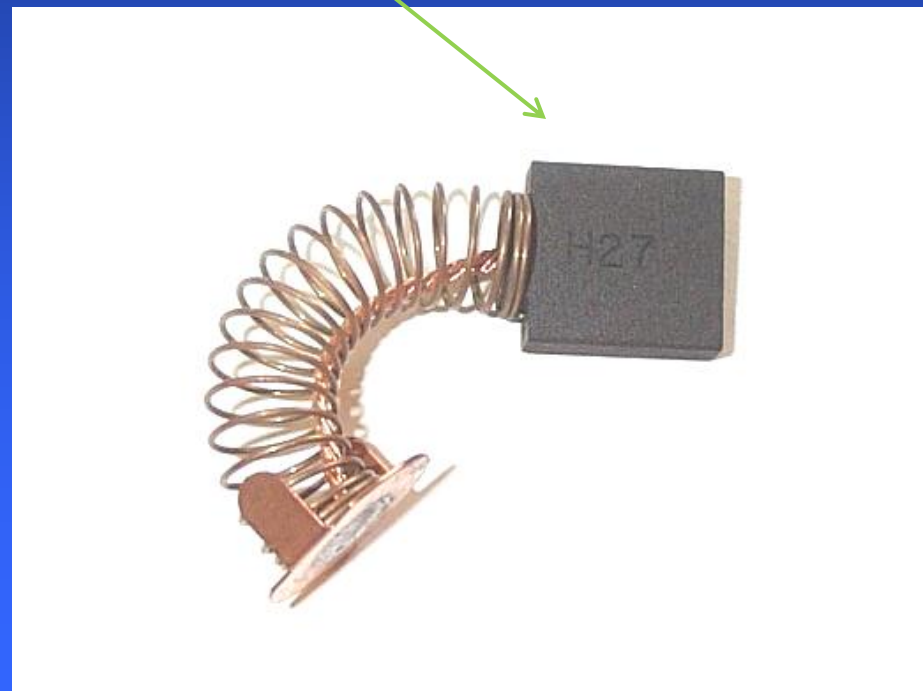

The simplest DC machine

3. The induced torque in the rotating loop

Assuming that a battery is connected to the DC machine, the force on a segment of a loop is:

$$F = i(\mathbf{l} \times \mathbf{B}) \quad (5.12.1)$$

And the torque on the segment is

$$\tau = rF \sin \theta \quad (5.12.2)$$

Where θ is the angle between r and F . Therefore, the torque is zero when the loop is beyond the pole edges.

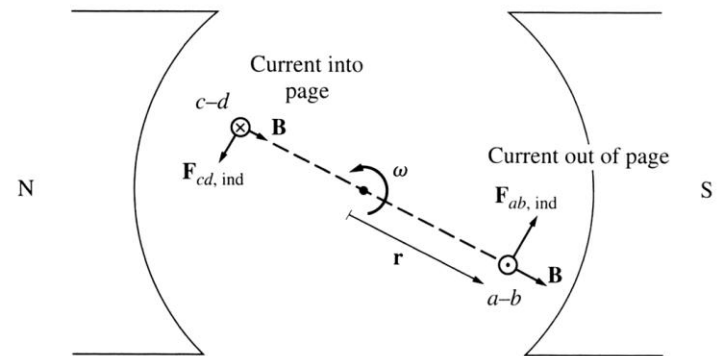
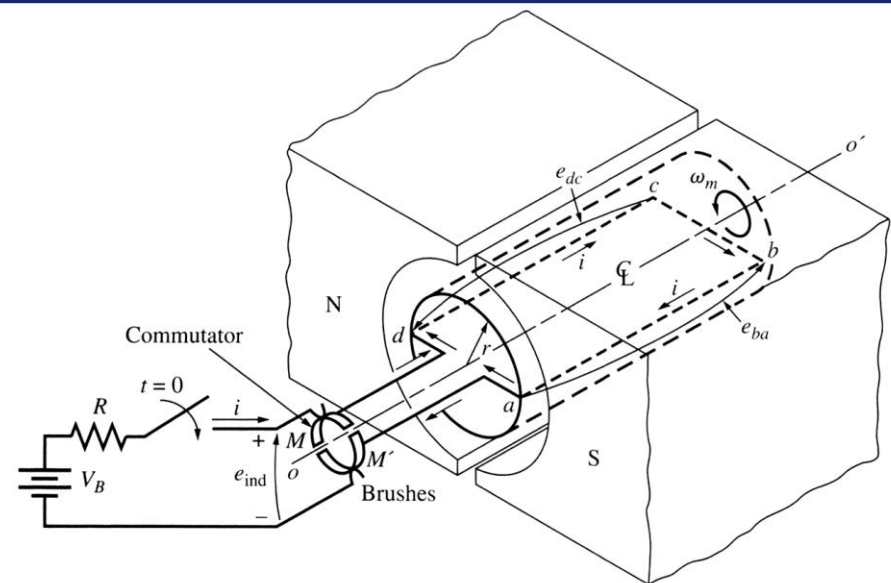

The simplest DC machine

When the loop is under the pole faces:

$$1. \text{ Segment } ab: \quad F_{ab} = i(\mathbf{1} \times \mathbf{B}) = ilB \quad (5.13.1)$$

$$\tau_{ab} = rF \sin \theta = r(ilB) \sin 90^\circ = rilB \quad ccw \quad (5.13.2)$$

$$2. \text{ Segment } bc: \quad F_{ab} = i(\mathbf{1} \times \mathbf{B}) = 0 \quad (5.13.3)$$

$$\tau_{ab} = rF \sin \theta = 0 \quad (5.13.4)$$

$$3. \text{ Segment } cd: \quad F_{ab} = i(\mathbf{1} \times \mathbf{B}) = ilB \quad (5.13.5)$$

$$\tau_{ab} = rF \sin \theta = r(ilB) \sin 90^\circ = rilB \quad ccw \quad (5.13.6)$$

$$4. \text{ Segment } da: \quad F_{ab} = i(\mathbf{1} \times \mathbf{B}) = 0 \quad (5.13.7)$$

$$\tau_{ab} = rF \sin \theta = 0 \quad (5.13.8)$$



The simplest DC machine

The resulting total induced torque is

$$\tau_{ind} = \tau_{ab} + \tau_{bc} + \tau_{cd} + \tau_{da} \quad (5.14.1)$$

$$\tau_{ind} = \begin{cases} 2rilB & \text{under the pole faces} \\ 0 & \text{beyond the pole edges} \end{cases} \quad (5.14.2)$$

Since $A_p \cong \pi rl$ and $\phi = A_p B$ (5.14.3)

$$\tau_{ind} = \begin{cases} \frac{2}{\pi} \phi i & \text{under the pole faces} \\ 0 & \text{beyond the pole edges} \end{cases} \quad (5.14.4)$$

The torque in any real machine depends on the following factors:

1. The flux inside the machine;
2. The current in the machine;
3. A constant representing the construction of the machine.



Commutation in a simple 4-loop DC machine

Commutation is the process of converting the AC voltages and currents in the rotor of a DC machine to DC voltages and currents at its terminals.

A simple 4-loop DC machine has four complete loops buried in slots curved in the laminated steel of its rotor. The pole faces are curved to make a uniform air-gap. The four loops are laid into the slots in a special manner: the innermost wire in each slot (end of each loop opposite to the “unprimed”) is indicated by a prime.

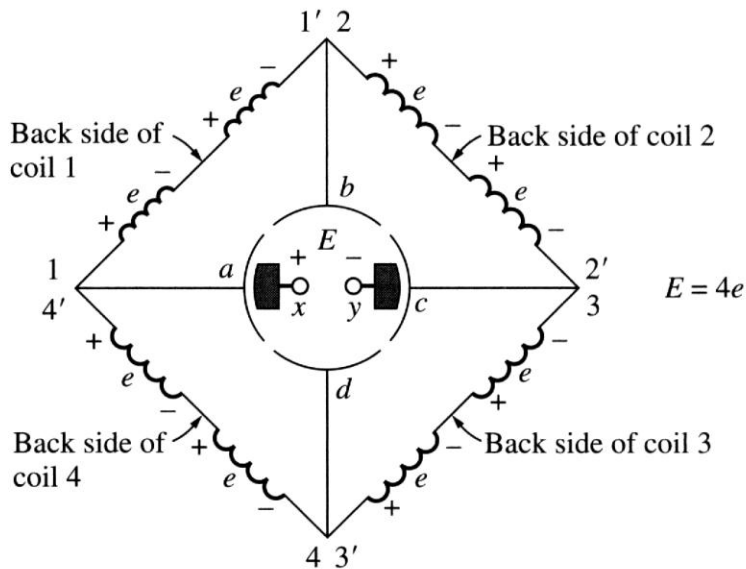
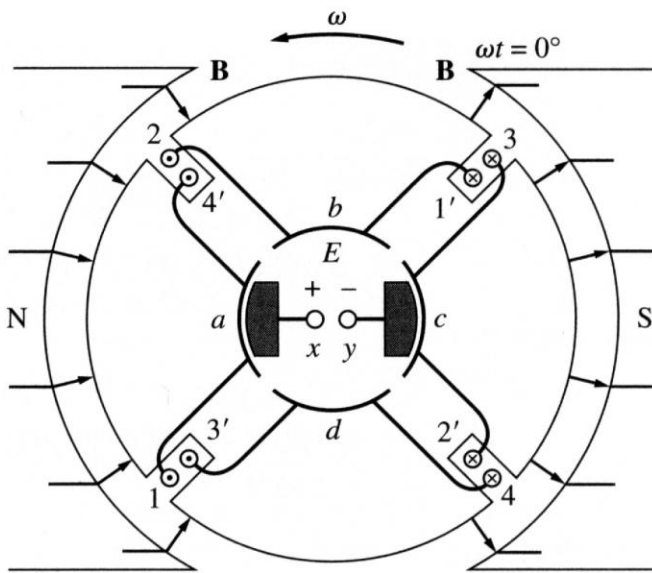

Loop 1 stretches between commutator segments *a* and *b*, loop 2 stretches between segments *b* and *c*...

Commutation in a simple 4-loop DC machine

At a certain time instance, when $\omega t = 0^\circ$, the 1, 2, 3', and 4' ends of the loops are under the north pole face and the 1', 2', 3, and 4 ends of the loops are under the south pole face. The voltage in each of 1, 2, 3', and 4' ends is given by

$$e_{ind} = (\mathbf{v} \times \mathbf{B}) \times \mathbf{l} = vBl \quad (5.16.1)$$

– positive, out of the page

The voltage in each of 1', 2', 3, and 4 ends is

$$e_{ind} = (\mathbf{v} \times \mathbf{B}) \times \mathbf{l} = vBl \quad \text{– positive, into the page} \quad (5.16.2)$$

If the induced voltage on any side of a loop is (5.16.1), the total voltage at the brushes of the DC machine is

$$E = 4e \quad \text{at } \omega t = 0^\circ \quad (5.16.3)$$

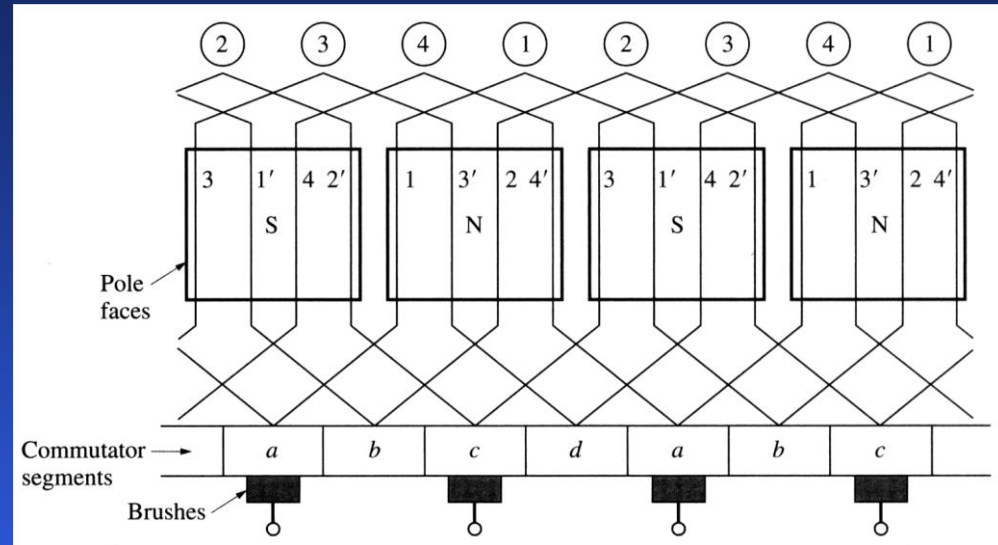

Commutation in a simple 4-loop DC machine

We notice that there are two parallel paths for current through the machine! The existence of two or more parallel paths for rotor current is a common feature of all commutation schemes.

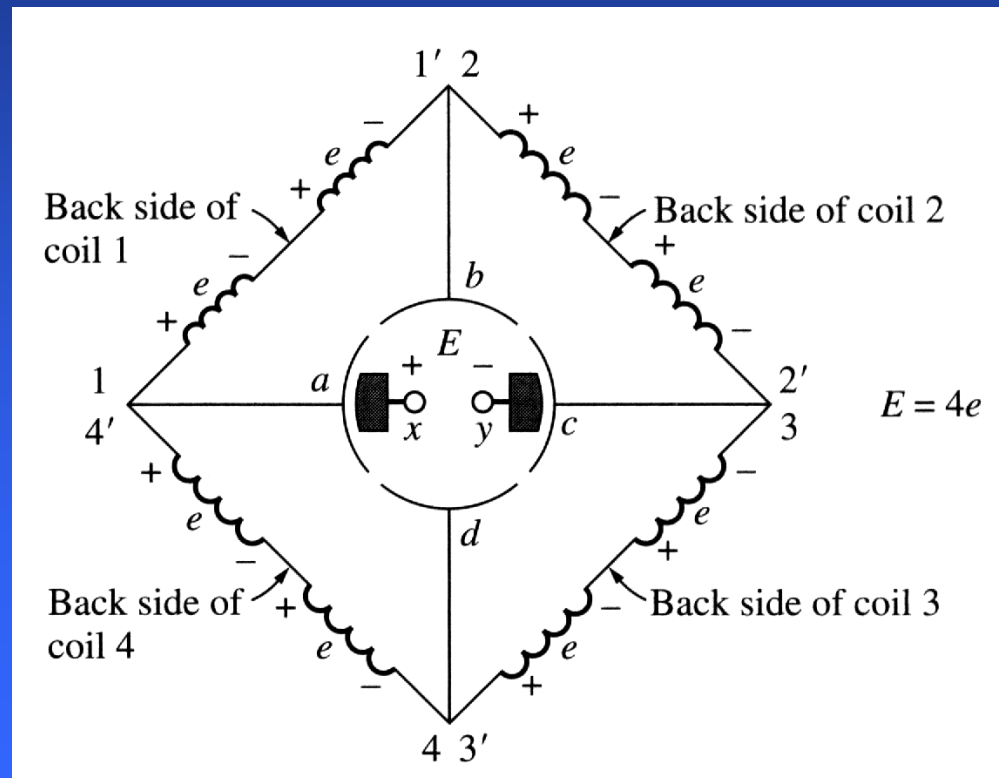

Commutation in a simple 4-loop DC machine

If the machine keeps rotating, at $\omega t = 45^\circ$, loops 1 and 3 have rotated into the gap between poles, so the voltage across each of them is zero. At the same time, the brushes short out the commutator segments ab and cd .

This is ok since the voltage across loops 1 and 3 is zero and only loops 2 and 4 are under the pole faces. Therefore, the total terminal voltage is

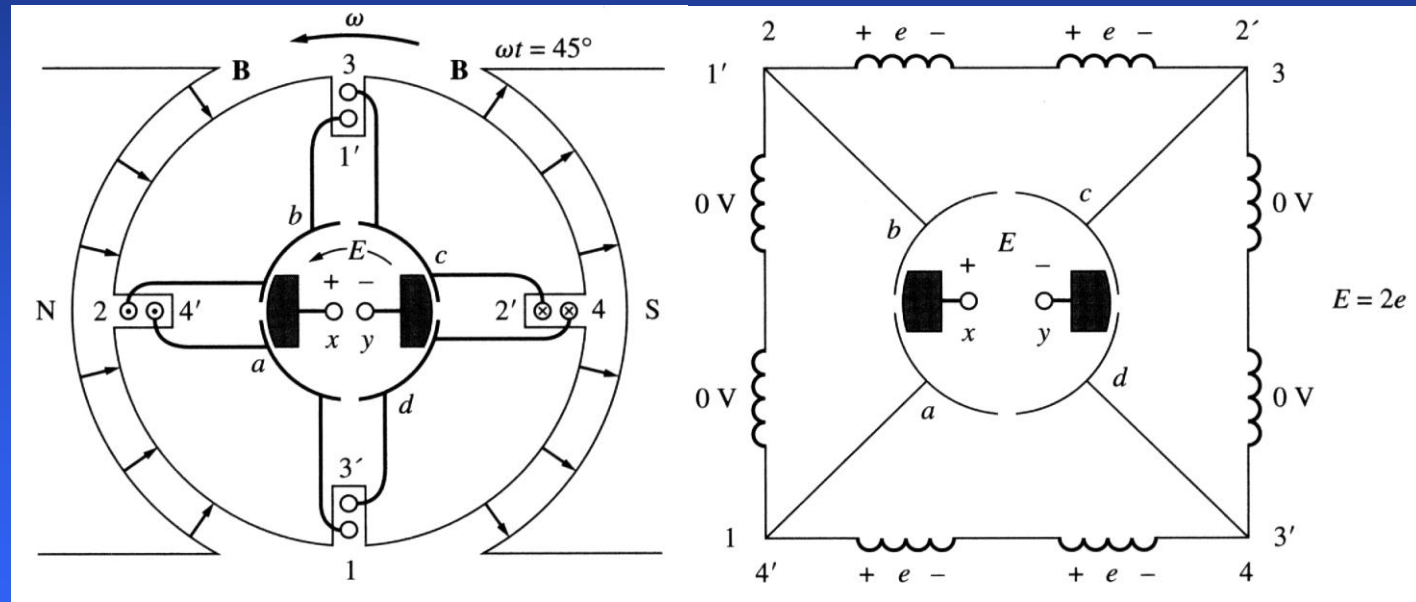

$$E = 2e \quad \text{at } \omega t = 45^\circ$$

(5.18.1)

Commutation in a simple 4-loop DC machine

At $\omega t = 90^\circ$, the loop ends 1', 2, 3, and 4' are under the north pole face, and the loop ends 1, 2', 3', and 4 are under the south pole face. The voltages are built up out of page for the ends under the north pole face and into the page for the ends under the south pole face. Four voltage-carrying ends in each parallel path through the machine lead to the terminal voltage of

$$E = 4e \quad \text{at } \omega t = 90^\circ \quad (5.16.3)$$

We notice that the voltages in loops 1 and 3 have reversed compared to $\omega t = 0^\circ$. However, the loops' connections have also reversed, making the total voltage being of the same polarity.

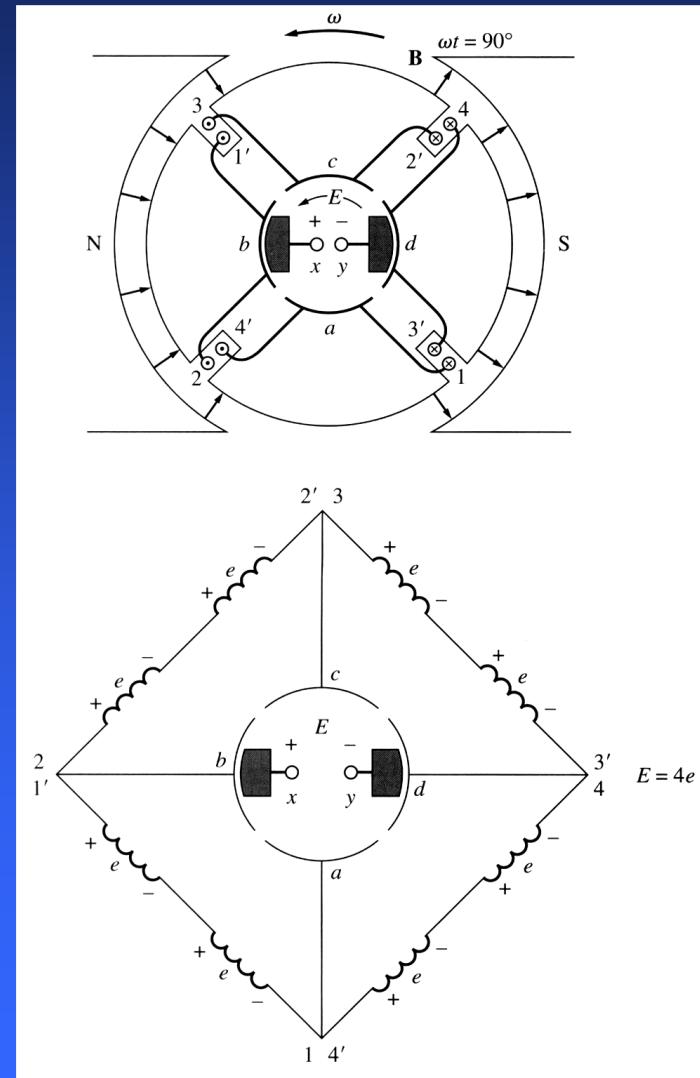

Commutation in a simple 4-loop DC machine

When the voltage reverses in a loop, the connections of the loop are also switched to keep the polarity of the terminal voltage the same.

The terminal voltage of this 4-loop DC machine is still not constant over time, although it is a better approximation to a constant DC level than what is produced by a single rotating loop.

Increasing the number of loops on the rotor, we improve our approximation to perfect DC voltage.

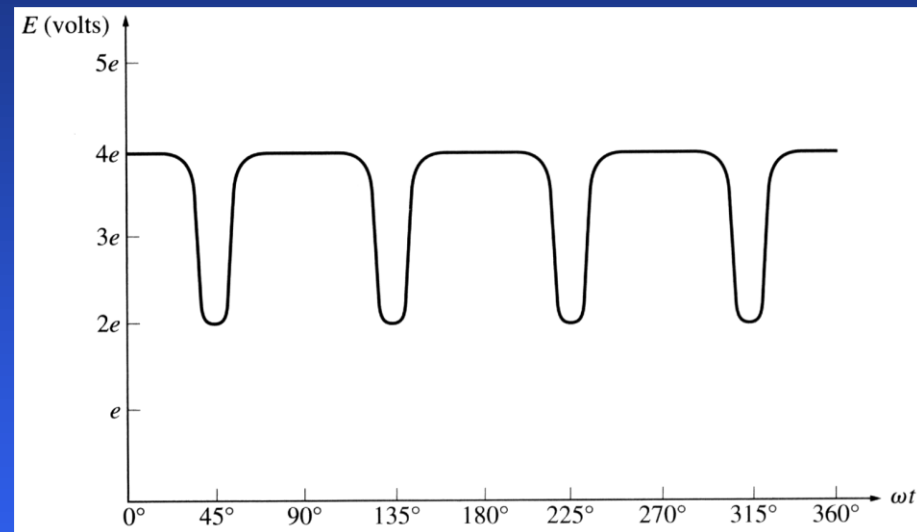

Commutator segments are usually made out of copper bars and the brushes are made of a mixture containing graphite to minimize friction between segments and brushes.



Example of a commutator...

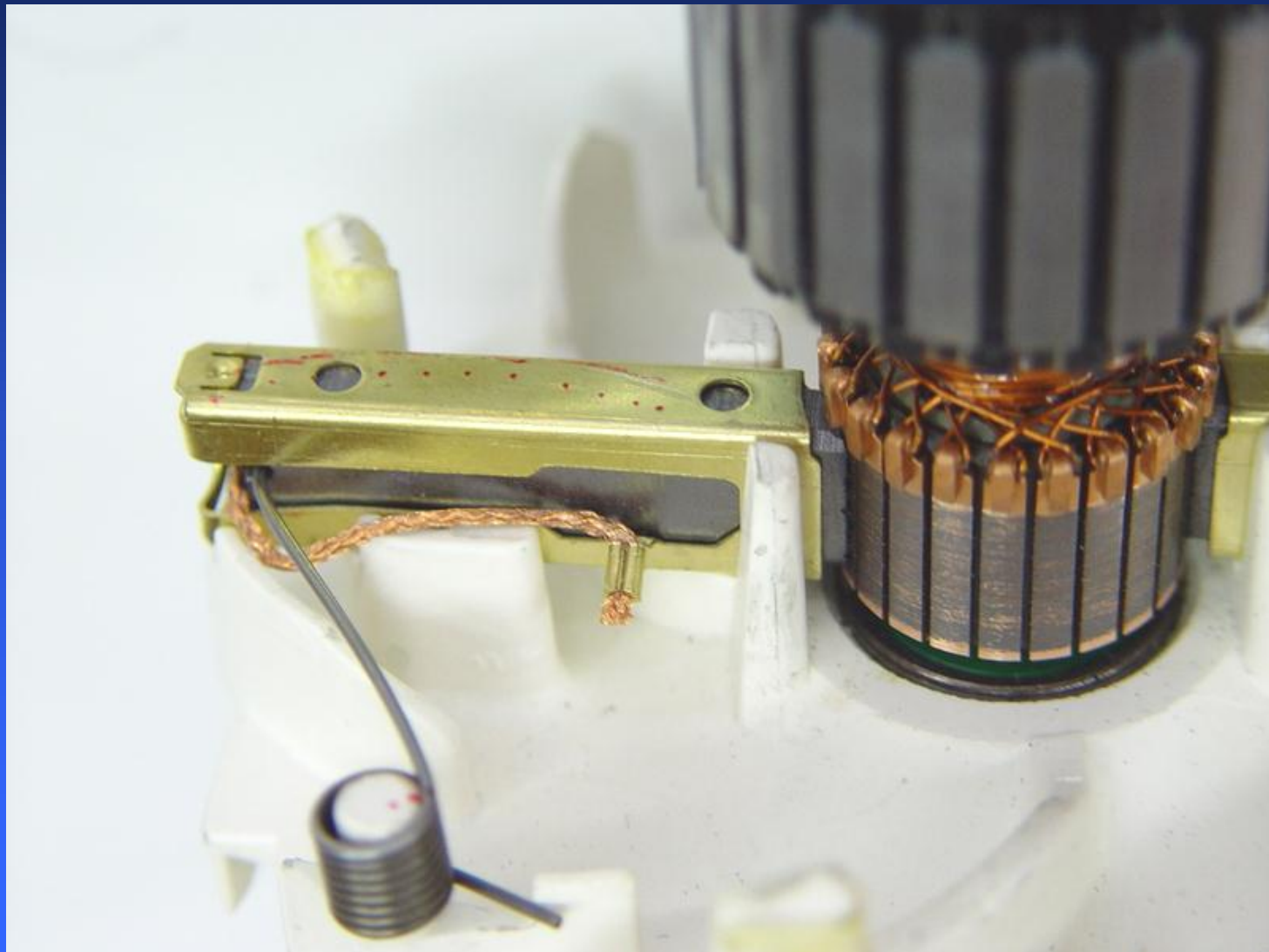

Problems with commutation in real DC machines

1. Armature reaction

If the magnetic field windings of a DC machine are connected to the power source and the rotor is turned by an external means, a voltage will be induced in the conductors of the rotor. This voltage is rectified and can be supplied to external loads. However, if a load is connected, a current will flow through the armature winding. This current produces its own magnetic field that distorts the original magnetic field from the machine's poles. This distortion of the machine's flux as the load increases is called armature reaction and can cause two problems:

1) neutral-plane shift: The magnetic neutral plane is the plane within the machine where the velocity of the rotor wires is exactly parallel to the magnetic flux lines, so that the induced voltage in the conductors in the plane is exactly zero.



Problems with commutation in real DC machines

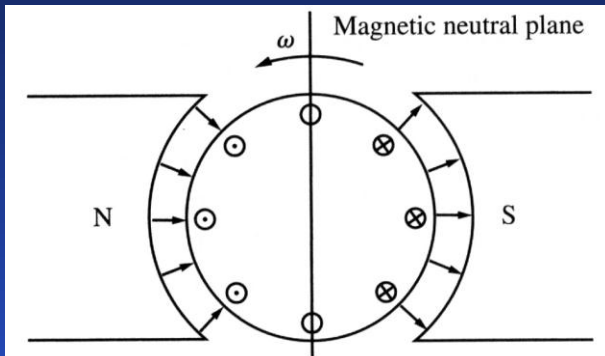

A two-pole DC machine: initially, the pole flux is uniformly distributed and the magnetic neutral plane is vertical.

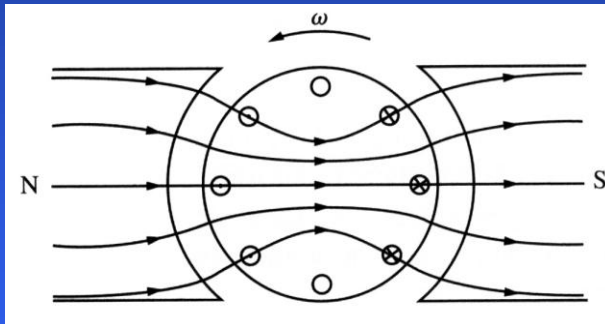

The effect of the air gap on the pole flux.

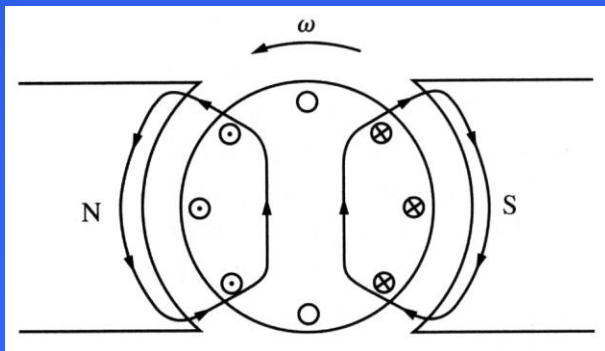

When the load is connected, a current – flowing through the rotor – will generate a magnetic field from the rotor windings.

Problems with commutation in real DC machines

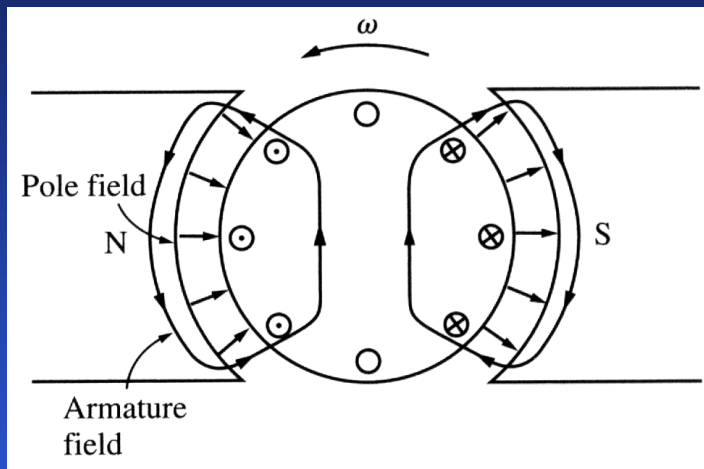

This rotor magnetic field will affect the original magnetic field from the poles. In some places under the poles, both fields will sum together, in other places, they will subtract from each other

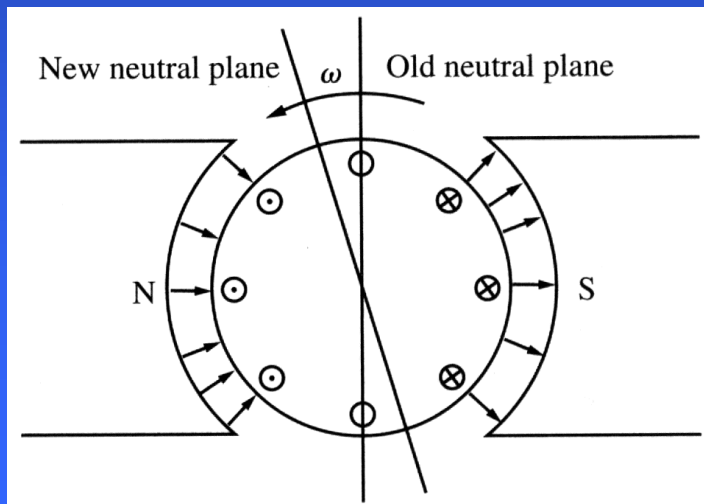

Therefore, the net magnetic field will not be uniform and the neutral plane will be shifted.

In general, the neutral plane shifts in the direction of motion for a generator and opposite to the direction of motion for a motor. The amount of the shift depends on the load of the machine.

Problems with commutation in real DC machines

The commutator must short out the commutator segments right at the moment when the voltage across them is zero. The neutral-plane shift may cause the brushes short out commutator segments with a non-zero voltage across them. This leads to arcing and sparking at the brushes!

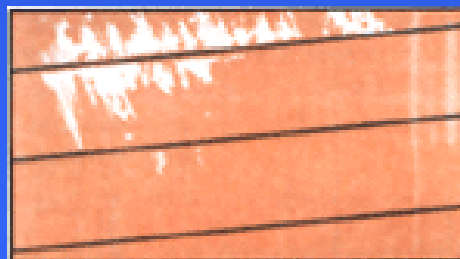

Problems with commutation in real DC machines

2) Flux weakening.

Most machines operate at flux densities near the saturation point.

At the locations on the pole surfaces where the rotor mmf adds to the pole mmf, only a small increase in flux occurs (due to saturation).

However, at the locations on the pole surfaces where the rotor mmf subtracts from the pole mmf, there is a large decrease in flux.

Therefore, the total average flux under the entire pole face decreases.

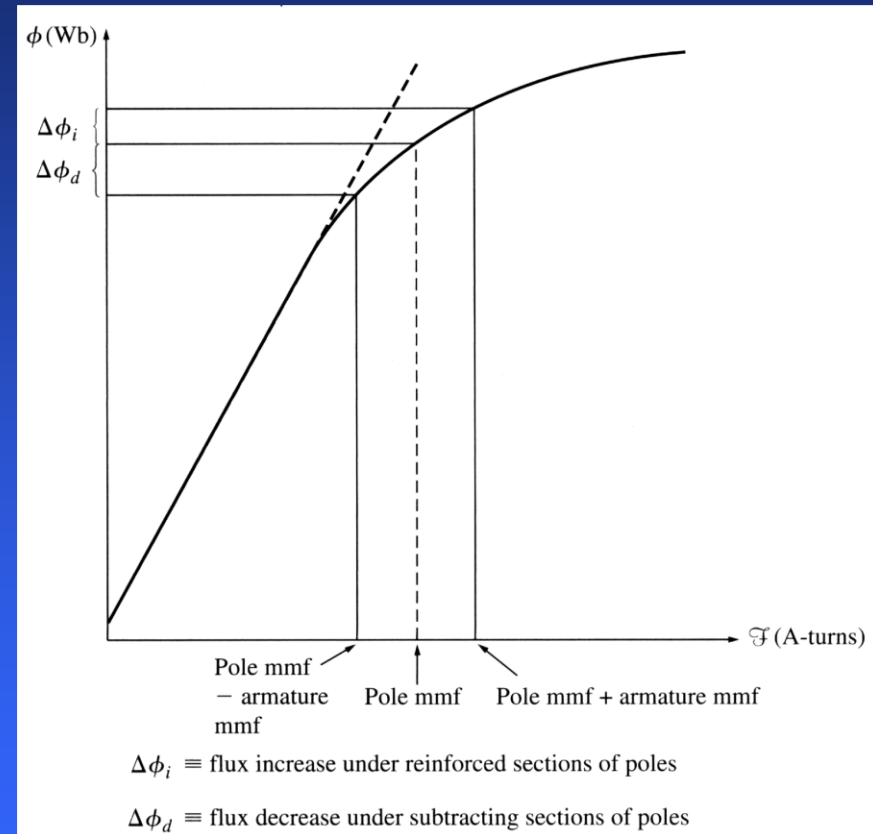

Problems with commutation in real DC machines

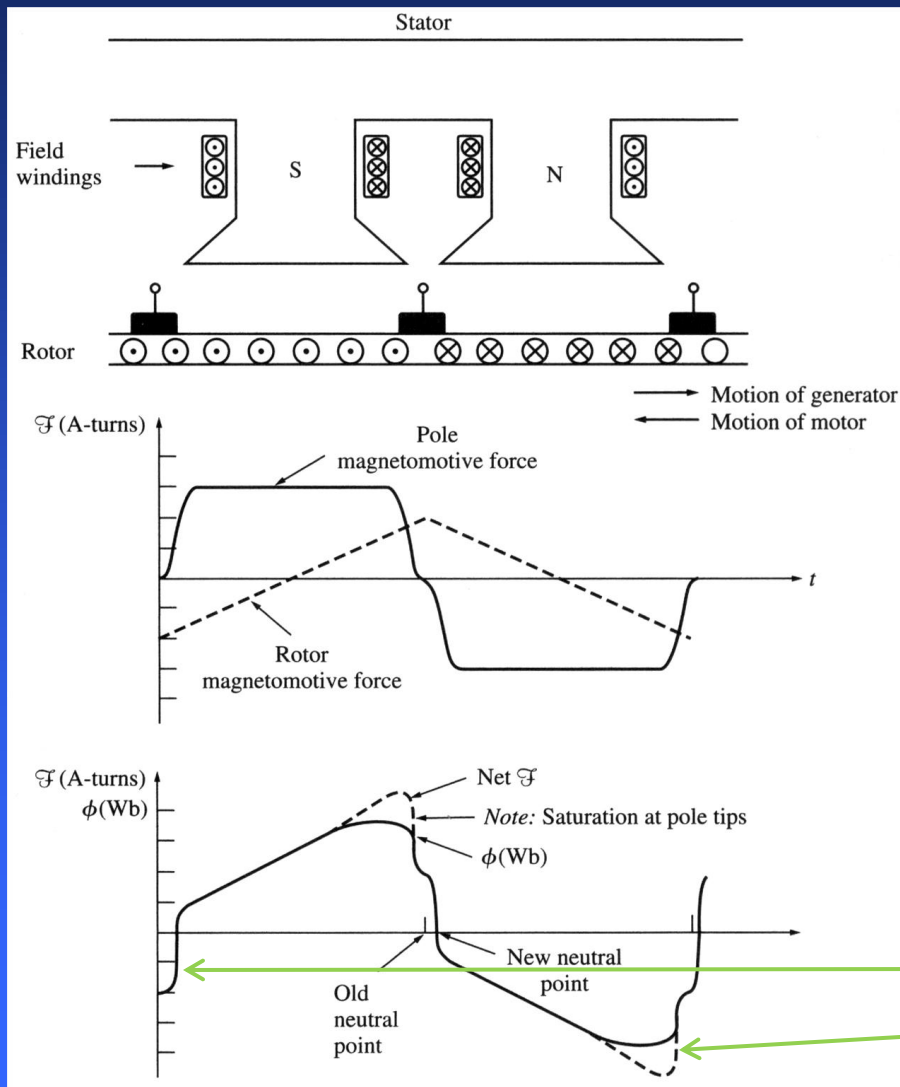

In generators, flux weakening reduces the voltage supplied by a generator.

In motors, flux weakening leads to increase of the motor speed.

Increase of speed may increase the load, which, in turns, results in more flux weakening. Some shunt DC motors may reach runaway conditions this way...

Observe a considerable decrease in the region where two mmfs are subtracted and a saturation...

Problems with commutation in real DC machines

2. $L di/dt$ voltages

This problem occurs in commutator segments being shorted by brushes and is called sometimes an inductive kick.

Assuming that the current in the brush is 400 A, the current in each path is 200 A. When a commutator segment is shorted out, the current flow through that segment must reverse.

Assuming that the machine is running at 800 rpm and has 50 commutator segments, each segment moves under the brush and clears it again in 0.0015 s.

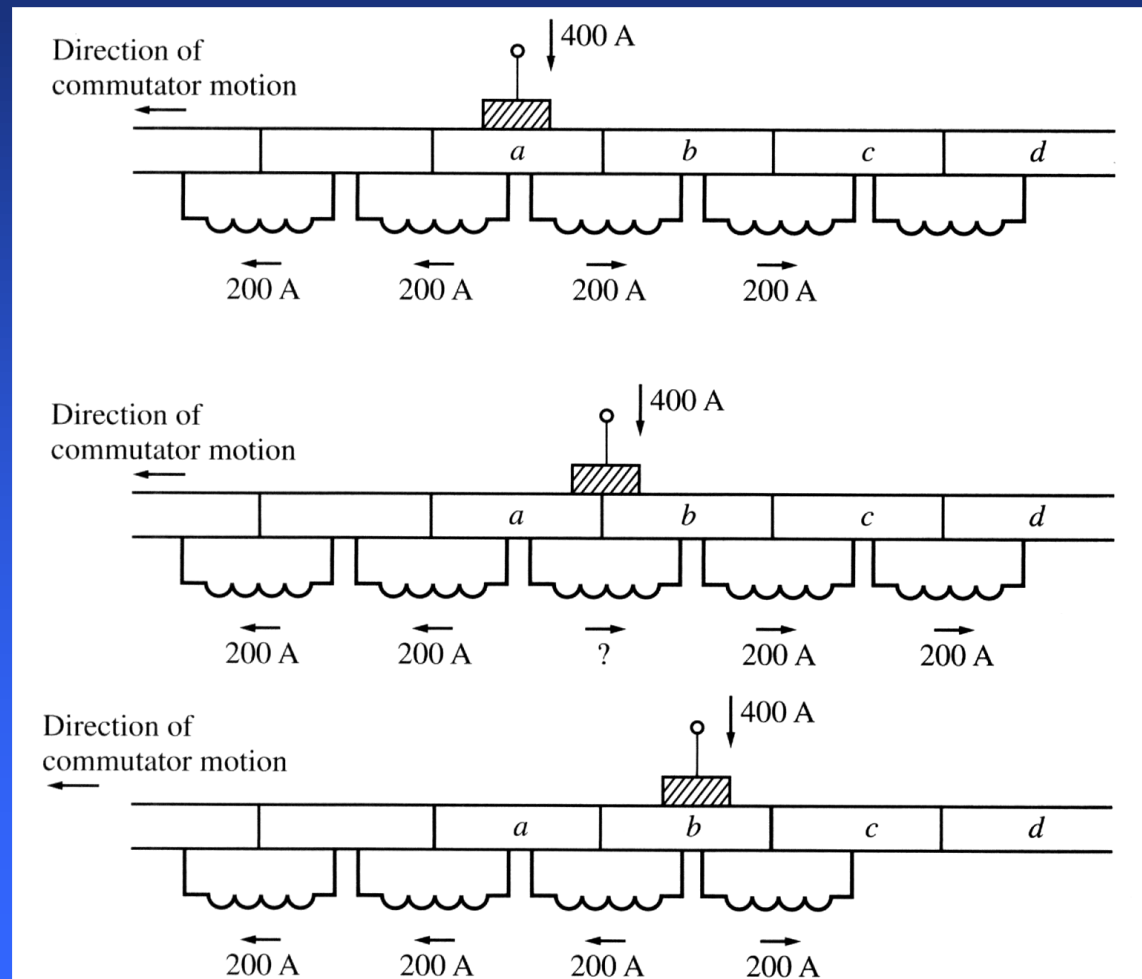

Problems with commutation in real DC machines

The rate of change in current in the shorted loop averages

$$\frac{di}{dt} = \frac{400}{0.0015} \approx 266\,667 \text{ A/s}$$

Therefore, even with a small inductance in the loop, a very large inductive voltage kick $L di/dt$ will be induced in the shorted commutator segment.

This voltage causes sparking at the brushes.

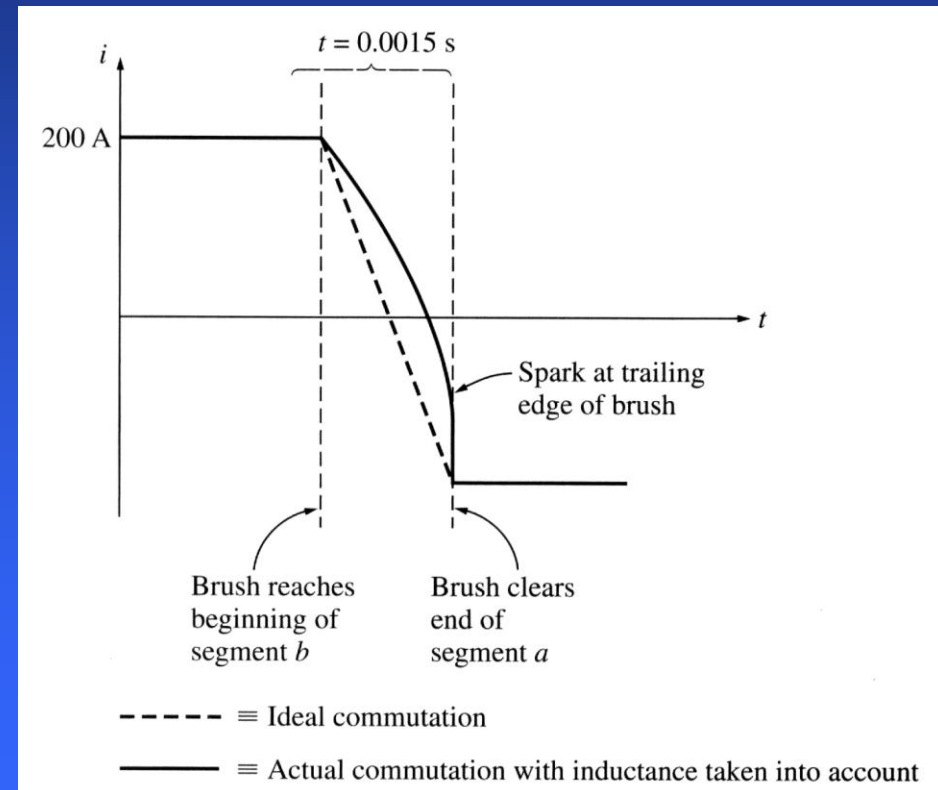

Solutions to the problems with commutation

1. Commutating poles or interpoles

To avoid sparking at the brushes while the machine's load changes, instead of adjusting the brushes' position, it is possible to introduce small poles (commutating poles or interpoles) between the main ones to make the voltage in the commutating wires to be zero. Such poles are located directly over the conductors being commutated and provide the flux that can exactly cancel the voltage in the coil undergoing commutation. Interpoles do not change the operation of the machine since they are so small that only affect few conductors being commutated. Flux weakening is unaffected.

Interpole windings are connected in series with the rotor windings. As the load increases and the rotor current increases, the magnitude of neutral-plane shift and the size of Ldi/dt effects increase too increasing the voltage in the conductors undergoing commutation.

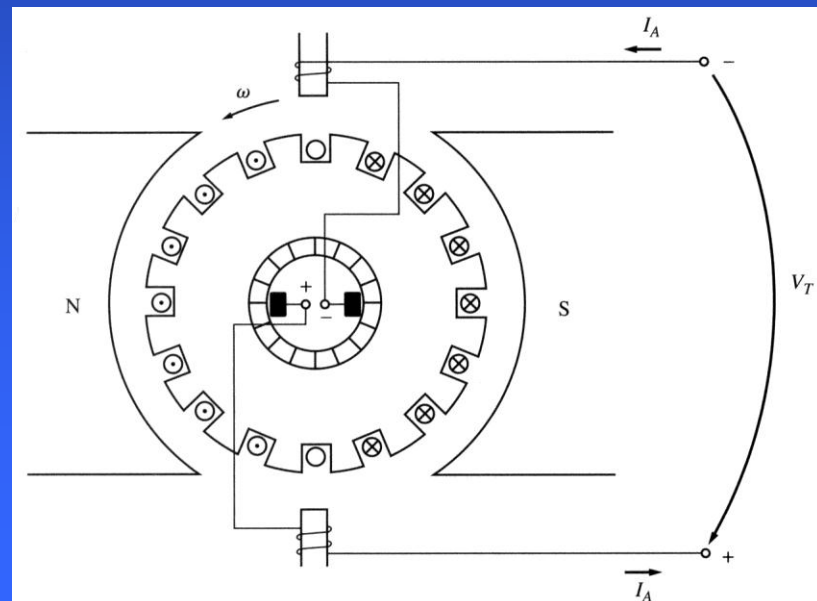

Solutions to the problems with commutation

However, the interpole flux increases too producing a larger voltage in the conductors that opposes the voltage due to neutral-plane shift. Therefore, both voltages cancel each other over a wide range of loads. This approach works for both DC motors and generators.

The interpoles must be of the same polarity as the next upcoming main pole in a generator;

The interpoles must be of the same polarity as the previous main pole in a motor.

The use of interpoles is very common because they correct the sparking problems of DC machines at a low cost. However, since interpoles do nothing with the flux distribution under the pole faces, flux-weakening problem is still present.

Solutions to the problems with commutation

2. Compensating windings

The flux weakening problem can be very severe for large DC motors. Therefore, compensating windings can be placed in slots carved in the faces of the poles parallel to the rotor conductors. These windings are connected in series with the rotor windings, so when the load changes in the rotor, the current in the compensating winding changes too...



Solutions to the problems with commutation

Pole flux

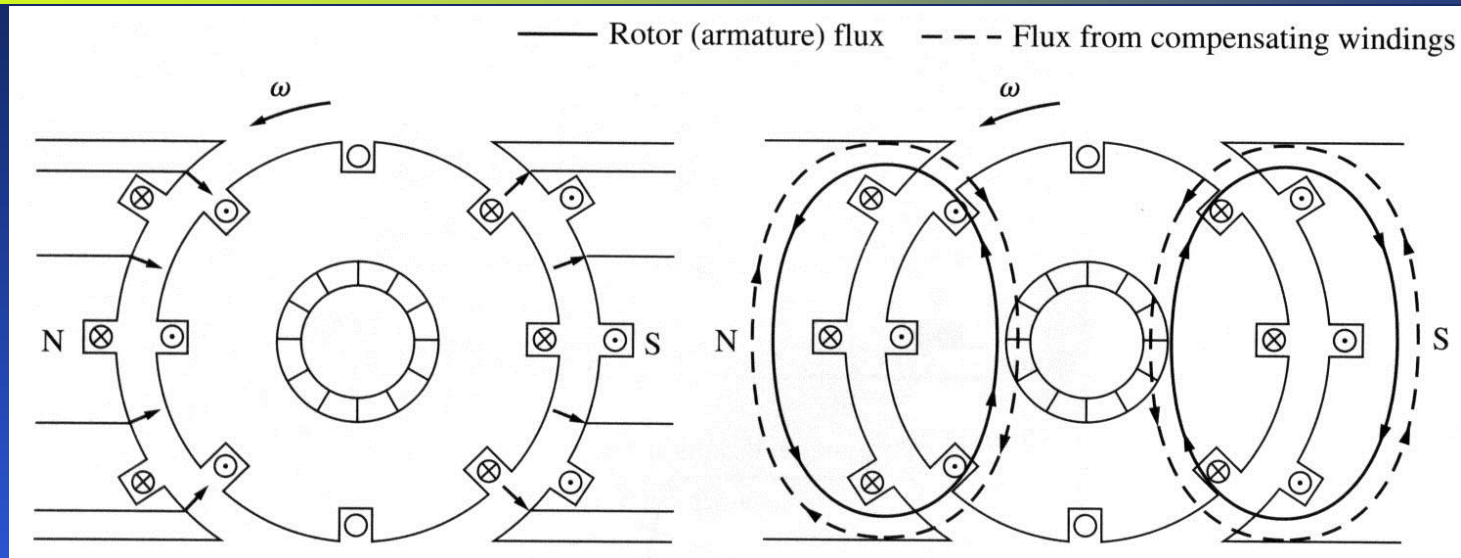

Rotor and comp. fluxes

Sum of these three fluxes equals to the original pole flux.

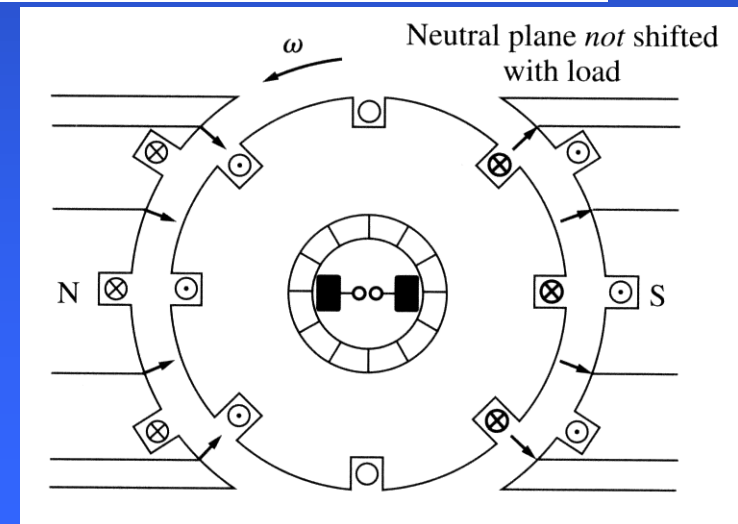

Solutions to the problems with commutation

The mmf due to the compensating windings is equal and opposite to the mmf of the rotor. These two mmfs cancel each other, such that the flux in the machine is unchanged.

The main disadvantage of compensating windings is that they are expensive since they must be machined into the faces of the poles. Also, any motor with compensative windings must have interpoles to cancel $L di/dt$ effects.

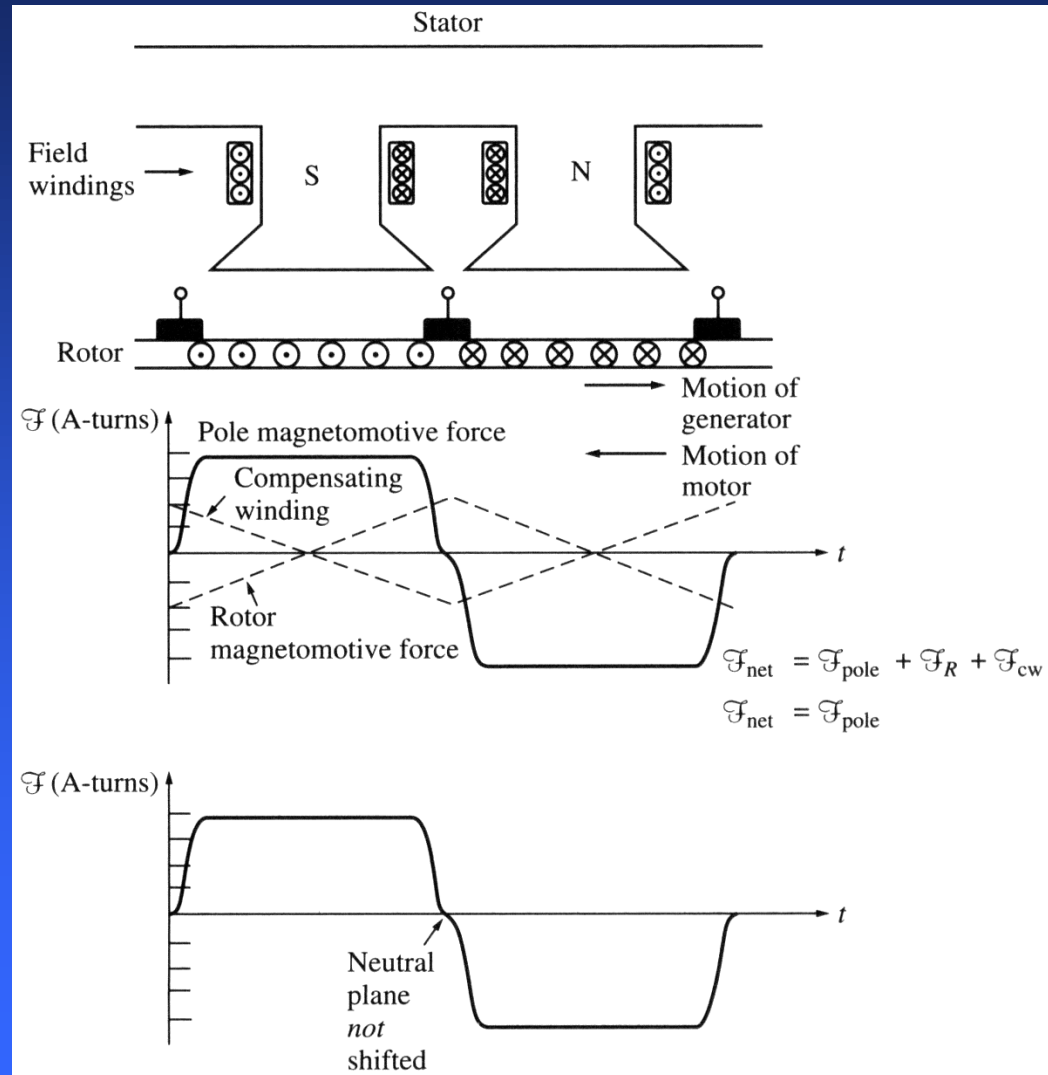

Solutions to the problems with commutation

A stator of a six-pole DC machine with interpoles and compensating windings.

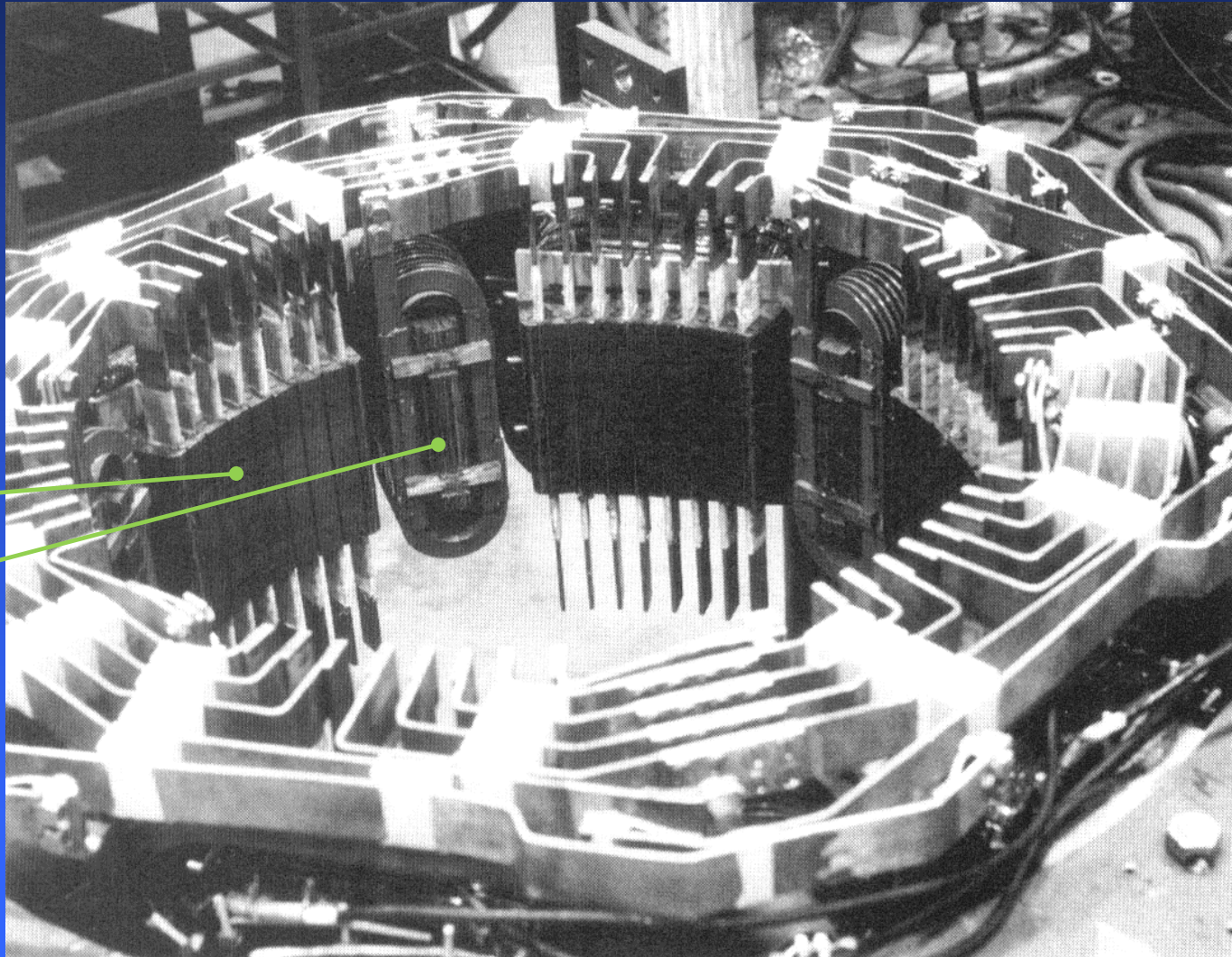

pole

interpole

Power flow and losses in DC machines

Unfortunately, not all electrical power is converted to mechanical power by a motor and not all mechanical power is converted to electrical power by a generator...

The efficiency of a DC machine is:

$$\eta = \frac{P_{out}}{P_{in}} \cdot 100\% \quad (5.36.1)$$

or

$$\eta = \frac{P_{in} - P_{loss}}{P_{in}} \cdot 100\% \quad (5.36.2)$$

The losses in DC machines

There are **five** categories of losses occurring in DC machines.

1. Electrical or copper losses – the resistive losses in the armature and field windings of the machine.

Armature loss:
$$P_A = I_A^2 R_A \quad (5.37.1)$$

Field loss:
$$P_F = I_F^2 R_F \quad (5.37.2)$$

Where I_A and I_F are armature and field currents and R_A and R_F are armature and field (winding) resistances usually measured at normal operating temperature.

The losses in DC machines

2. Brush (drop) losses – the power lost across the contact potential at the brushes of the machine.

$$P_{BD} = V_{BD} I_A \quad (5.38.1)$$

Where I_A is the armature current and V_{BD} is the brush voltage drop. The voltage drop across the set of brushes is approximately constant over a large range of armature currents and it is usually assumed to be about 2 V.

Other losses are exactly the same as in AC machines...

The losses in DC machines

3. Core losses – hysteresis losses and eddy current losses. They vary as B^2 (square of flux density) and as $n^{1.5}$ (speed of rotation of the magnetic field).
4. Mechanical losses – losses associated with mechanical effects: friction (friction of the bearings) and windage (friction between the moving parts of the machine and the air inside the casing). These losses vary as the cube of rotation speed n^3 .
5. Stray (Miscellaneous) losses – losses that cannot be classified in any of the previous categories. They are usually due to inaccuracies in modeling. For many machines, stray losses are assumed as 1% of full load.



The power-flow diagram

One of the most convenient techniques to account for power losses in a machine is the power-flow diagram.

For a DC motor:

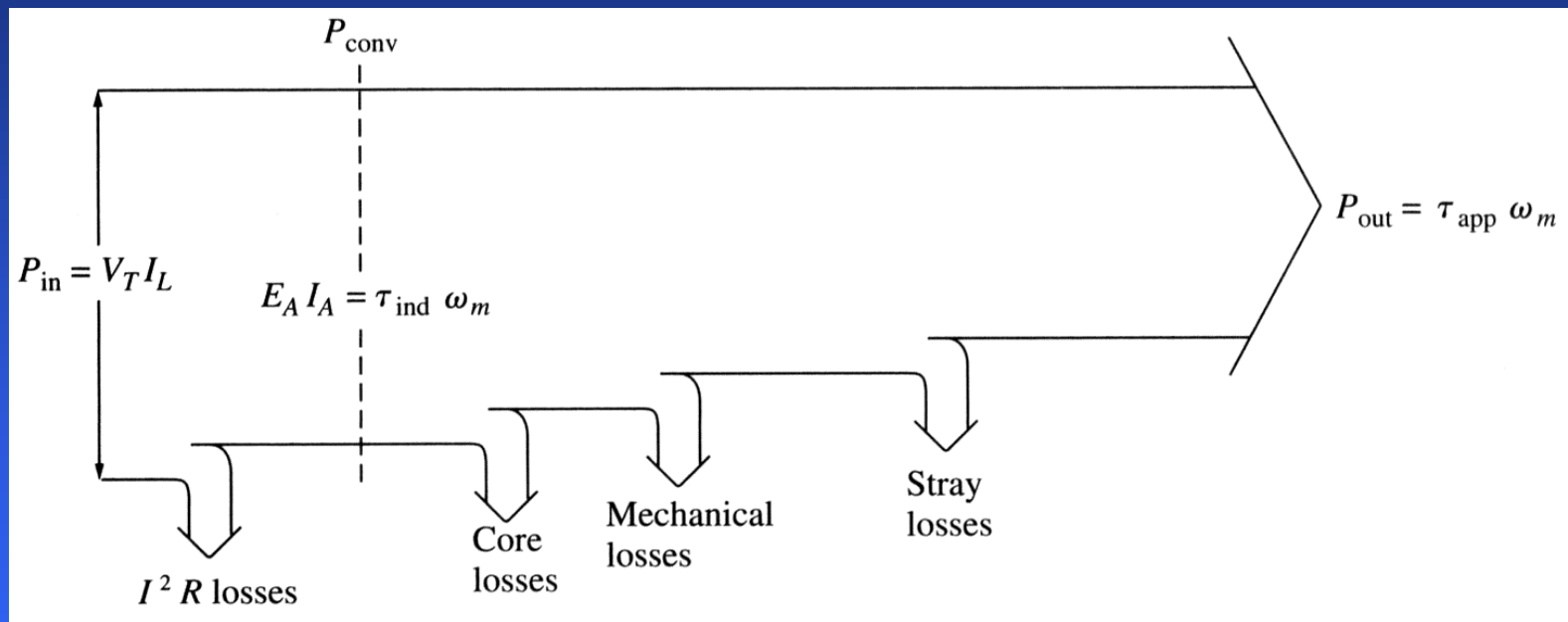

Electrical power is input to the machine, and the electrical and brush losses must be subtracted. The remaining power is ideally converted from electrical to mechanical form at the point labeled as P_{conv} .

The power-flow diagram

The electrical power that is converted is

$$P_{conv} = E_A I_A \quad (5.41.1)$$

And the resulting mechanical power is

$$P_{conv} = \tau_{ind} \omega_m \quad (5.41.2)$$

After the power is converted to mechanical form, the stray losses, mechanical losses, and core losses are subtracted, and the remaining mechanical power is output to the load.



Equivalent circuit of a DC motor

The armature circuit (the entire rotor structure) is represented by an ideal voltage source E_A and a resistor R_A . A battery V_{brush} in the opposite to a current flow in the machine direction indicates brush voltage drop.

The field coils producing the magnetic flux are represented by inductor L_F and resistor R_F . The resistor R_{adj} represents an external variable resistor (sometimes lumped together with the field coil resistance) used to control the amount of current in the field circuit.

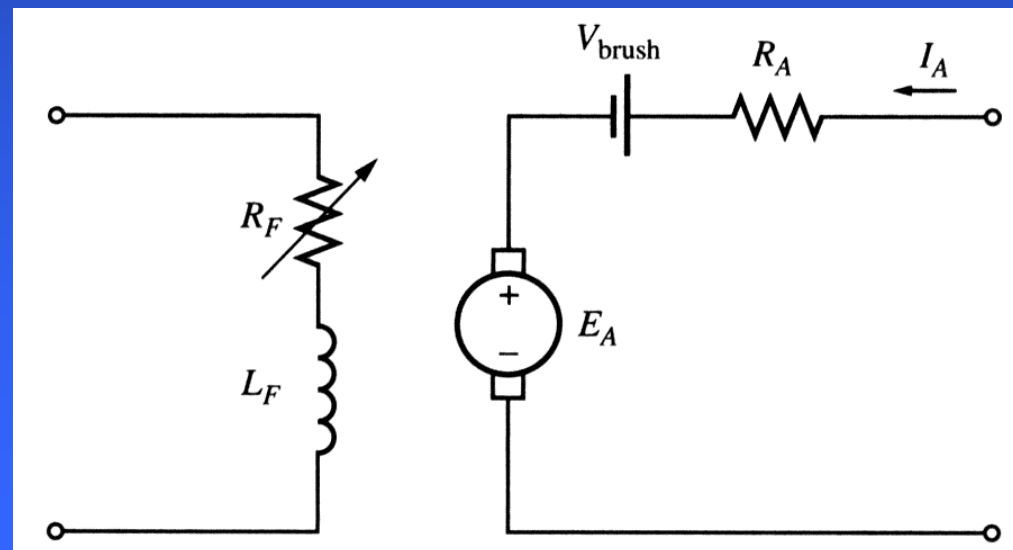
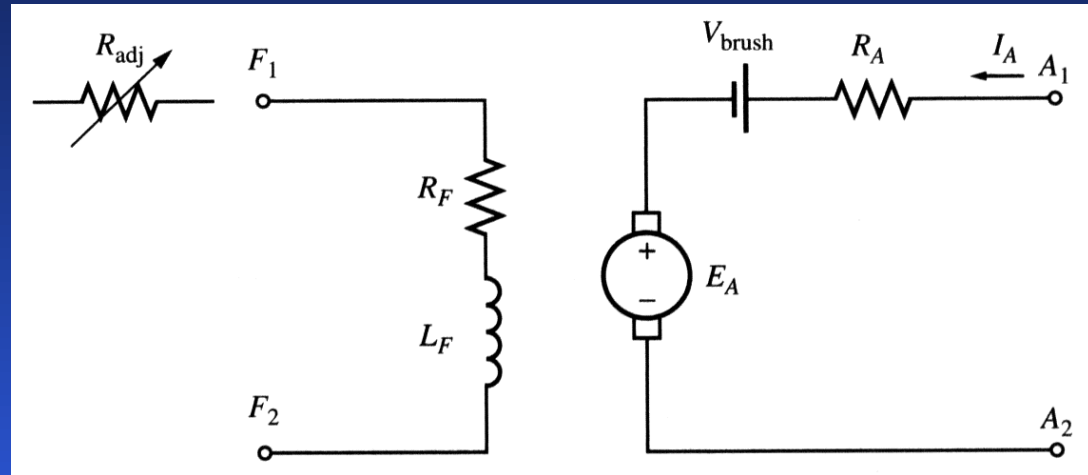

Equivalent circuit of a DC motor

Sometimes, when the brush drop voltage is small, it may be left out. Also, some DC motors have more than one field coil...

The internal generated voltage in the machine is

$$E_A = K\phi\omega \quad (5.43.1)$$

The induced torque developed by the machine is

$$\tau_{ind} = K\phi I_A \quad (5.43.2)$$

Here K is the constant depending on the design of a particular DC machine (number and commutation of rotor coils, etc.) and ϕ is the total flux inside the machine.

Note that for a single rotating loop $K = \pi/2$.

Magnetization curve of a DC machine

The internal generated voltage E_A is directly proportional to the flux in the machine and the speed of its rotation.

The field current in a DC machine produces a field mmf $\mathcal{F} = N_F I_F$, which produces a flux in the machine according to the magnetization curve.

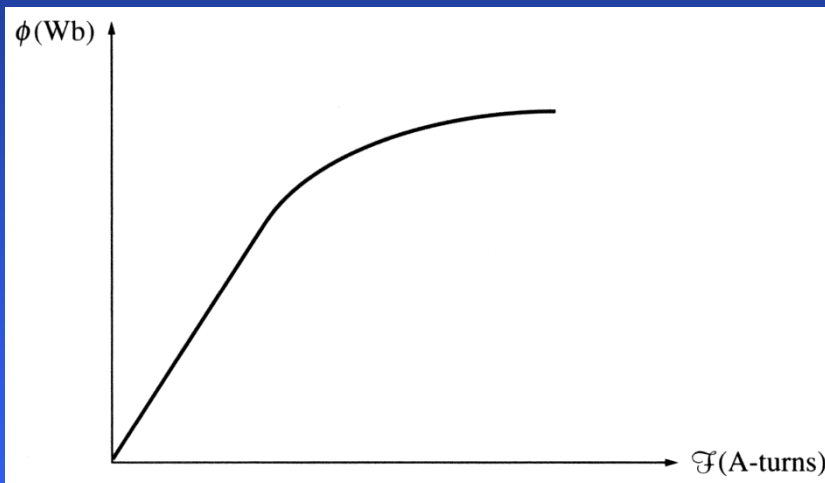

or in terms
of internal
voltage vs.
field
current for
a given
speed.

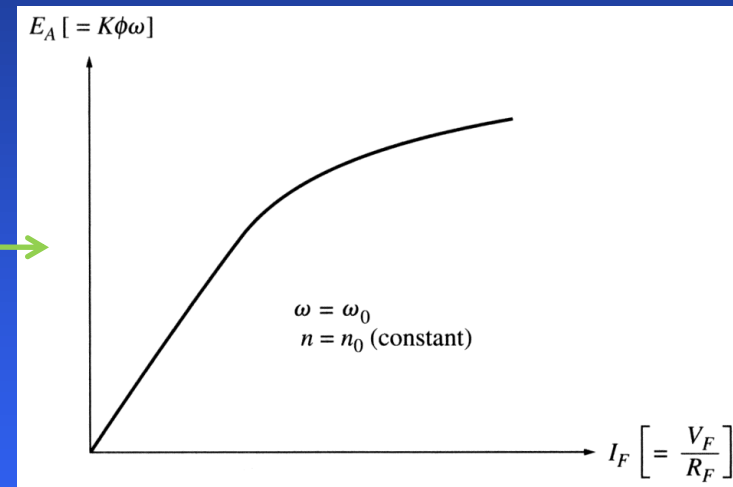

To get the maximum possible power per weight out of the machine, most motors and generators are operating near the saturation point on the magnetization curve. Therefore, when operating at full load, often a large increase in current I_F may be needed for small increases in the generated voltage E_A .

Motor types: Separately excited and Shunt DC motors

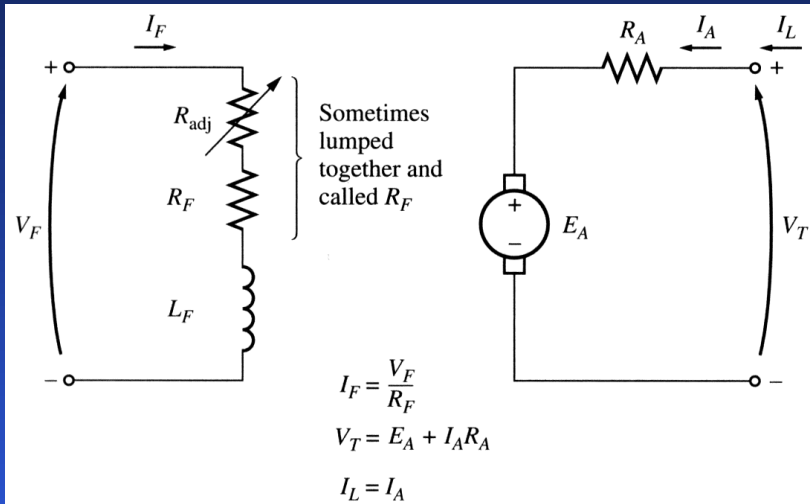

Note: when the voltage to the field circuit is assumed constant, there is no difference between them...

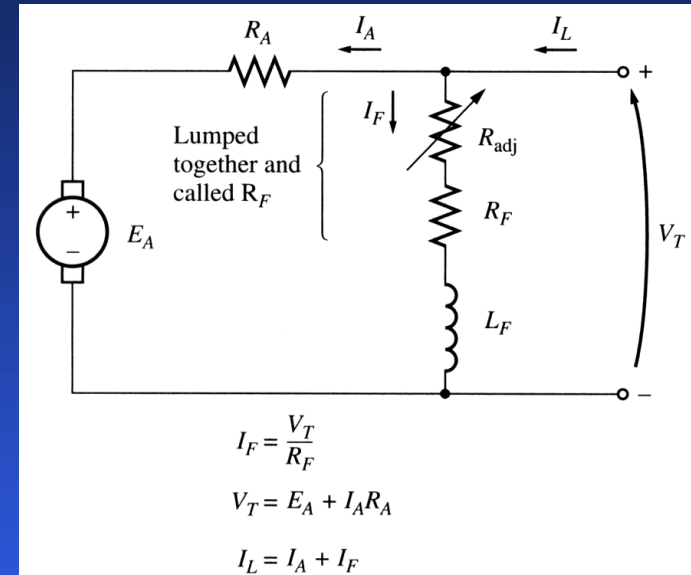

Separately excited DC motor:
a field circuit is supplied from a separate constant voltage power source.

Shunt DC motor:
a field circuit gets its power from the armature terminals of the motor.

For the armature circuit of these motors:

$$V_T = E_A + I_A R_A$$

(5.45.1)

Shunt motor: terminal characteristic

A terminal characteristic of a machine is a plot of the machine's output quantities vs. each other.

For a motor, the output quantities are shaft torque and speed. Therefore, the terminal characteristic of a motor is its output torque vs. speed.

If the load on the shaft increases, the load torque τ_{load} will exceed the induced torque τ_{ind} , and the motor will slow down. Slowing down the motor will decrease its internal generated voltage (since $E_A = K\phi\omega$), so the armature current increases ($I_A = (V_T - E_A)/R_A$). As the armature current increases, the induced torque in the motor increases (since $\tau_{ind} = K\phi I_A$), and the induced torque will equal the load torque at a lower speed ω .

$$\omega = \frac{V_T}{K\phi} - \frac{R_A}{(K\phi)^2} \tau_{ind}$$

(5.46.1)



Shunt motor: terminal characteristic

Assuming that the terminal voltage and other terms are constant, the motor's speed vary linearly with torque.

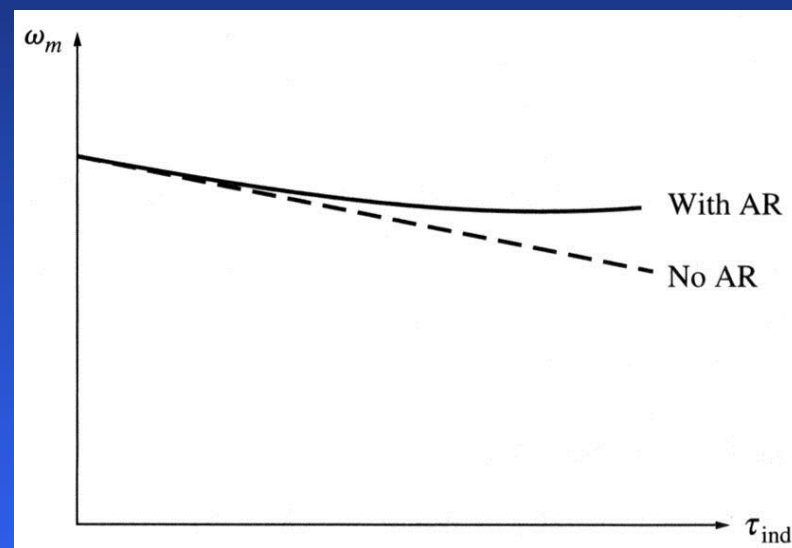
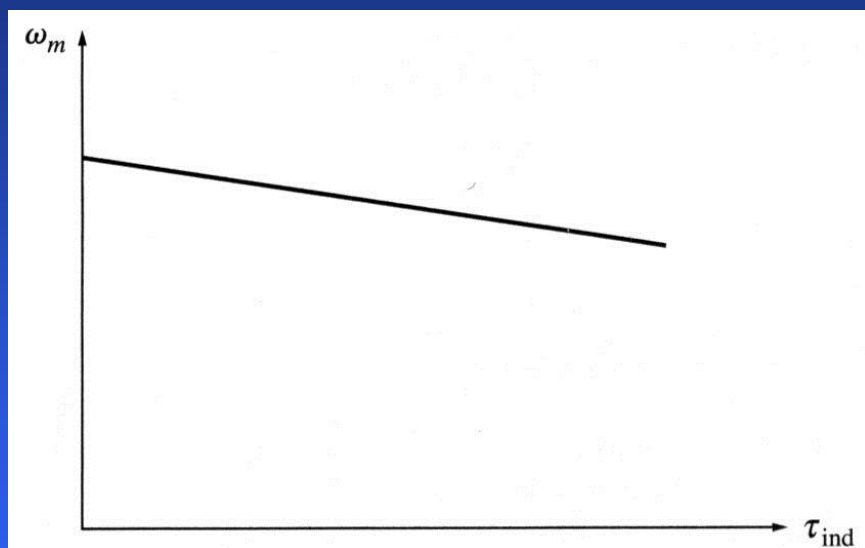

However, if a motor has an armature reaction, flux-weakening reduces the flux when torque increases. Therefore, the motor's speed will increase. If a shunt (or separately excited) motor has compensating windings, and the motor's speed and armature current are known for any value of load, it's possible to calculate the speed for any other value of load.

Shunt motor: terminal characteristic

– Example

Example 5.1: A 50 hp, 250 V, 1200 rpm DC shunt motor **with** compensating windings has an armature resistance (including the brushes, compensating windings, and interpoles) of 0.06Ω . Its field circuit has a total resistance $R_{adj} + R_F$ of 50Ω , which produces a no-load speed of 1200 rpm. The shunt field winding has 1200 turns per pole.

- Find the motor speed when its input current is 100 A.
- Find the motor speed when its input current is 200 A.
- Find the motor speed when its input current is 300 A.
- Plot the motor torque-speed characteristic.

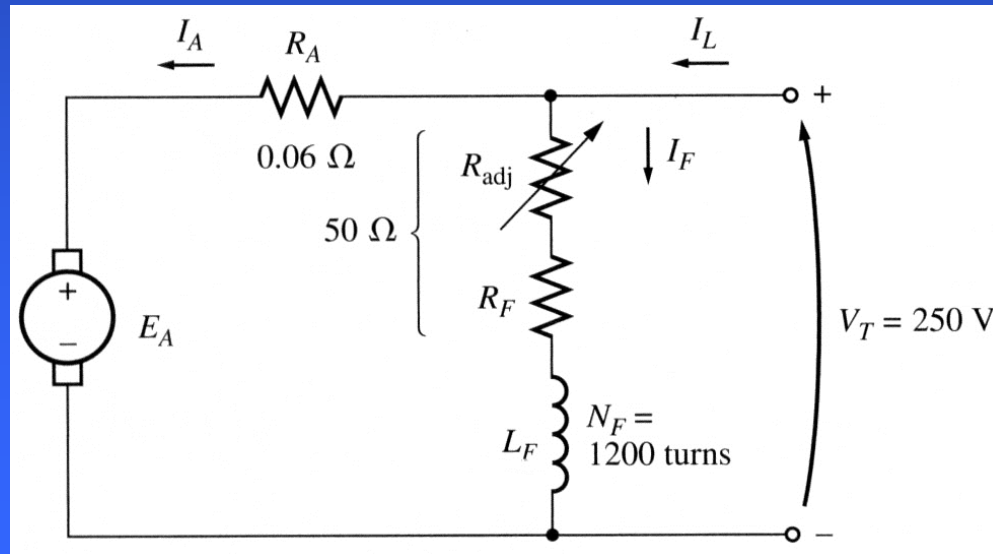

Shunt motor: terminal characteristic

– Example

The internal generated voltage of a DC machine (with its speed expressed in rpm):

$$E_A = K\phi\omega$$

Since the field current is constant (both field resistance and V_T are constant) and since there are no armature reaction (due to compensating windings), we conclude that the flux in the motor is constant. The speed and the internal generated voltages at different loads are related as

$$\frac{E_{A2}}{E_{A1}} = \frac{K\phi\omega_2}{K\phi\omega_1} = \frac{n_2}{n_1}$$

Therefore:

$$n_2 = \frac{E_{A2}}{E_{A1}} n_1$$

At no load, the armature current is zero and therefore $E_{A1} = V_T = 250$ V.



Shunt motor: terminal characteristic

– Example

a) Since the input current is 100 A, the armature current is

$$I_A = I_L - I_F = I_L - \frac{V_T}{R_F} = 100 - \frac{250}{50} = 95 \text{ A}$$

Therefore: $E_A = V_T - I_A R_A = 250 - 95 \cdot 0.06 = 244.3 \text{ V}$

and the resulting motor speed is:

$$n_2 = \frac{E_{A2}}{E_{A1}} n_1 = \frac{244.3}{250} 1200 = 1173 \text{ rpm}$$

b) Similar computations for the input current of 200 A lead to $n_2 = 1144 \text{ rpm}$.

c) Similar computations for the input current of 300 A lead to $n_2 = 1115 \text{ rpm}$.

d) To plot the output characteristic of the motor, we need to find the torque corresponding to each speed. At no load, the torque is zero.



Shunt motor: terminal characteristic

– Example

Since the induced torque at any load is related to the power converted in a DC motor:

$$P_{conv} = E_A I_A = \tau_{ind} \omega$$

the induced torque is

$$\tau_{ind} = \frac{E_A I_A}{\omega}$$

For the input current of 100 A:

$$\tau_{ind} = \frac{2443 \cdot 95}{2\pi \cdot 1173 / 60} = 190 \text{ N} \cdot \text{m}$$

For the input current of 200 A:

$$\tau_{ind} = \frac{2383 \cdot 195}{2\pi \cdot 1144 / 60} = 388 \text{ N} \cdot \text{m}$$

For the input current of 300 A:

$$\tau_{ind} = \frac{2323 \cdot 295}{2\pi \cdot 1115 / 60} = 587 \text{ N} \cdot \text{m}$$



Shunt motor: terminal characteristic

– Example

The torque-speed characteristic of the motor is:

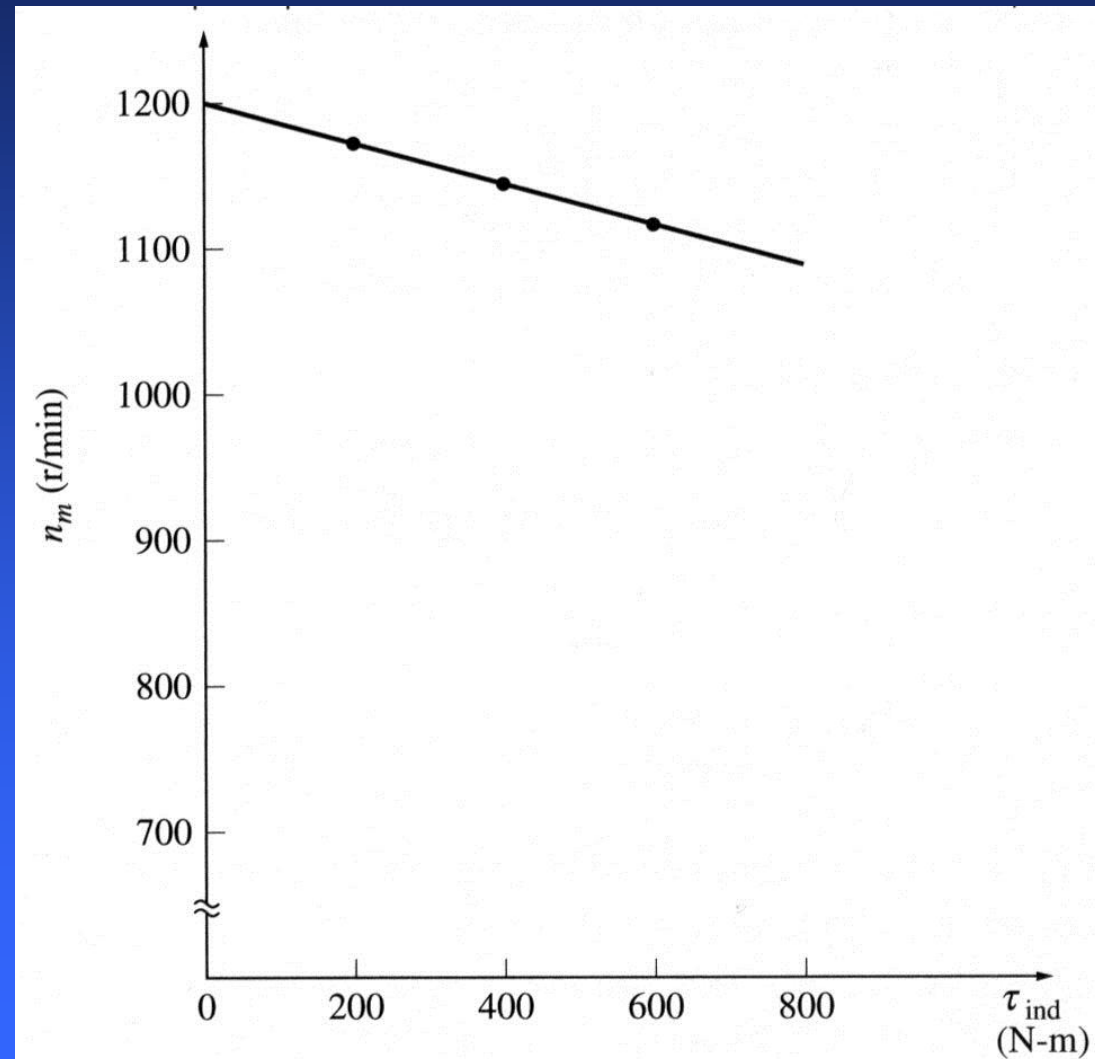

Shunt motor: Nonlinear analysis

The flux ϕ and, therefore the internal generated voltage E_A of a DC machine are nonlinear functions of its mmf and must be determined based on the magnetization curve. Two main contributors to the mmf are its field current and the armature reaction (if present).

Since the magnetization curve is a plot of the generated voltage vs. field current, the effect of changing the field current can be determined directly from the magnetization curve.

If a machine has armature reaction, its flux will reduce with increase in load. The total mmf in this case will be

$$F_{net} = N_F I_F - F_{AR} \quad (5.53.1)$$

It is customary to define an equivalent field current that would produce the same output voltage as the net (total) mmf in the machine:

$$I_F^* = I_F - \frac{F_{AR}}{N_F} \quad (5.53.2)$$

Shunt motor: Nonlinear analysis

Conducting a nonlinear analysis to determine the internal generated voltage in a DC motor, we may need to account for the fact that a motor can be running at a speed other than the rated one.

The voltage induced in a DC machine is

$$E_A = K\phi\omega \quad (5.54.1)$$

For a given effective field current, the flux in the machine is constant and the internal generated voltage is directly proportional to speed:

$$\frac{E_A}{E_{A0}} = \frac{n}{n_0} \quad (5.54.2)$$

Where E_{A0} and n_0 represent the reference (rated) values of voltage and speed, respectively. Therefore, if the reference conditions are known from the magnetization curve and the actual E_A is computed, the actual speed can be determined.



Shunt motor: Nonlinear analysis – Example

Example 5.2: A 50 hp, 250 V, 1200 rpm DC shunt motor **without** compensating windings has an armature resistance (including the brushes and interpoles) of 0.06Ω . Its field circuit has a total resistance $R_{adj} + R_F$ of 50Ω , which produces a no-load speed of 1200 rpm. The shunt field winding has 1200 turns per pole. The armature reaction produces a demagnetizing mmf of 840 A-turns at a load current of 200 A. The magnetization curve is shown.

- Find the motor speed when its input current is 200 A.
- How does the motor speed compare to the speed of the motor from Example 5.1 (same motor but **with** compensating windings) with an input current of 200 A?
- Plot the motor torque-speed characteristic.

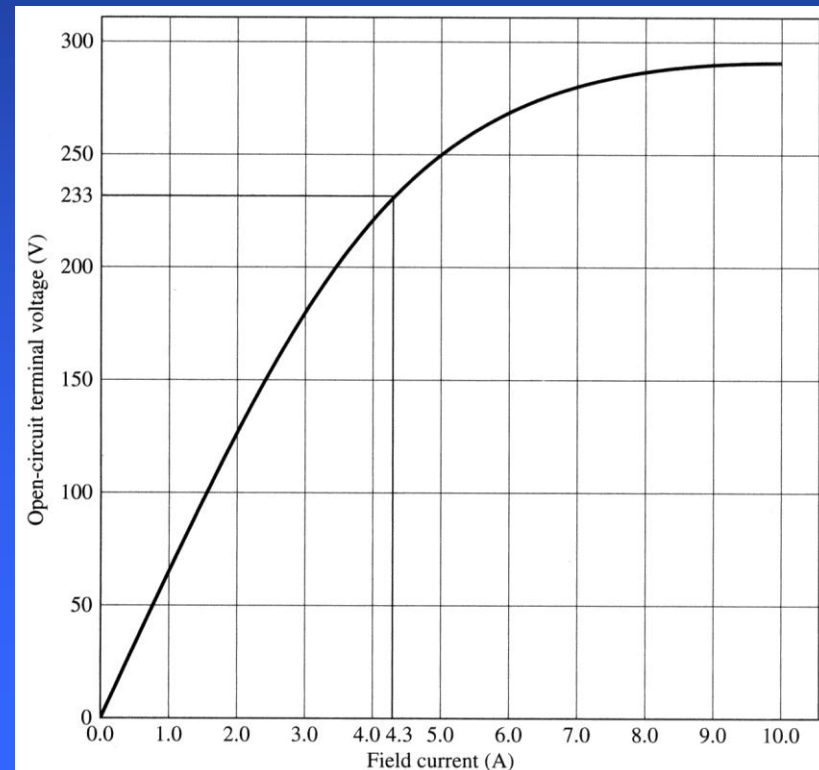

Shunt motor: Nonlinear analysis – Example

a) Since the input current is 200 A, the armature current is

$$I_A = I_L - I_F = I_L - \frac{V_T}{R_F} = 200 - \frac{250}{50} = 195 \text{ A}$$

Therefore: $E_A = V_T - I_A R_A = 250 - 195 \cdot 0.06 = 238.3 \text{ V}$

At the given current, the demagnetizing mmf due to armature reaction is 840 A-turns, so the effective shunt field current of the motor is

$$I_F^* = I_F - \frac{F_{AR}}{N_F} = 5 - \frac{840}{1200} = 4.3 \text{ A}$$

From the magnetization curve, this effective field current will produce an internal voltage of $E_{A0} = 233 \text{ V}$ at a speed of 1200 rpm. For the actual voltage, the speed is

$$n = \frac{E_A}{E_{A0}} n_0 = \frac{238.3}{233} 1200 = 1227 \text{ rpm}$$

Shunt motor: Nonlinear analysis – Example

b) A speed of a motor with compensating windings was 1144 rpm when the input current was 200 A. We notice that the speed of the motor with armature reactance is higher than the speed of the motor without armature reactance. This increase is due to the flux weakening.

c) Assuming that the mmf due to the armature reaction varies linearly with the increase in current, and repeating the same computations for many different load currents, the motor's torque-speed characteristic can be plotted.

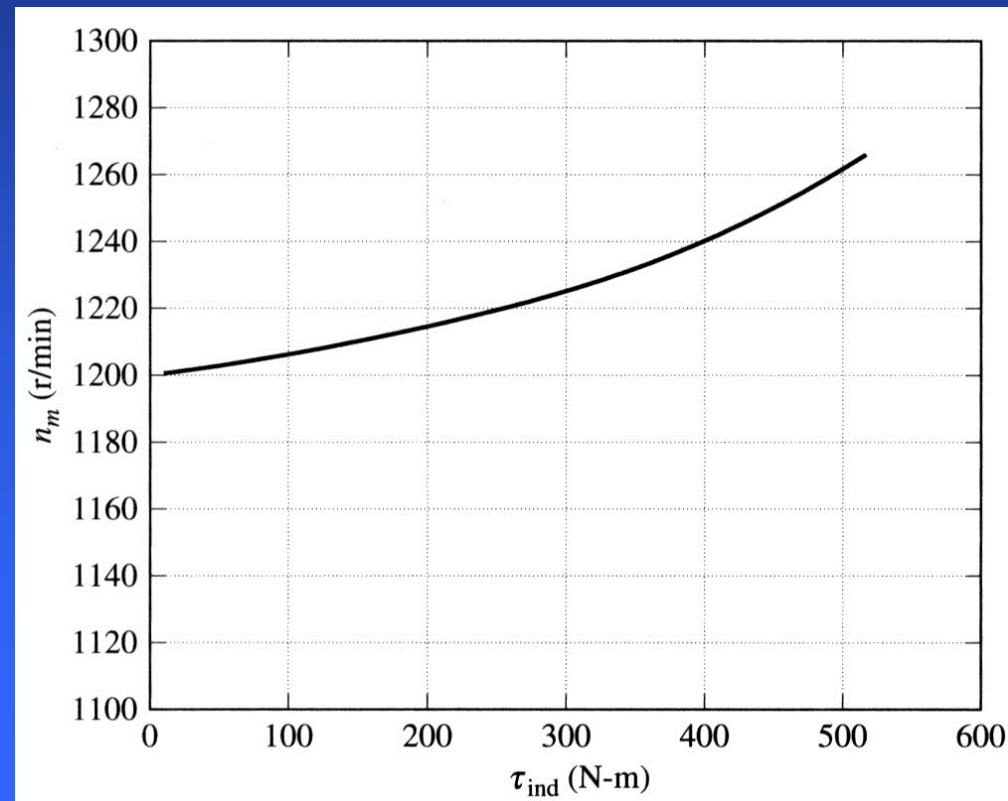

Shunt motor: Speed control

There are two methods to control the speed of a shunt DC motor:

1. Adjusting the field resistance R_F (and thus the field flux)
2. Adjusting the terminal voltage applied to the armature

1. Adjusting the field resistance

- 1) Increasing field resistance R_F decreases the field current ($I_F = V_T/R_F$);
- 2) Decreasing field current I_F decreases the flux ϕ ;
- 3) Decreasing flux decreases the internal generated voltage ($E_A = K\phi\omega$);
- 4) Decreasing E_A increases the armature current ($I_A = (V_T - E_A)/R_A$);
- 5) Changes in armature current dominate over changes in flux; therefore, increasing I_A increases the induced torque ($\tau_{ind} = K\phi I_A$);
- 6) Increased induced torque is now larger than the load torque τ_{load} and, therefore, the speed ω increases;
- 7) Increasing speed increases the internal generated voltage E_A ;
- 8) Increasing E_A decreases the armature current I_A ...
- 9) Decreasing I_A decreases the induced torque until $\tau_{ind} = \tau_{load}$ at a higher speed ω .

Shunt motor: Speed control

The effect of increasing the field resistance within a normal load range: from no load to full load.

Increase in the field resistance increases the motor speed. Observe also that the slope of the speed-torque curve becomes steeper when field resistance increases.

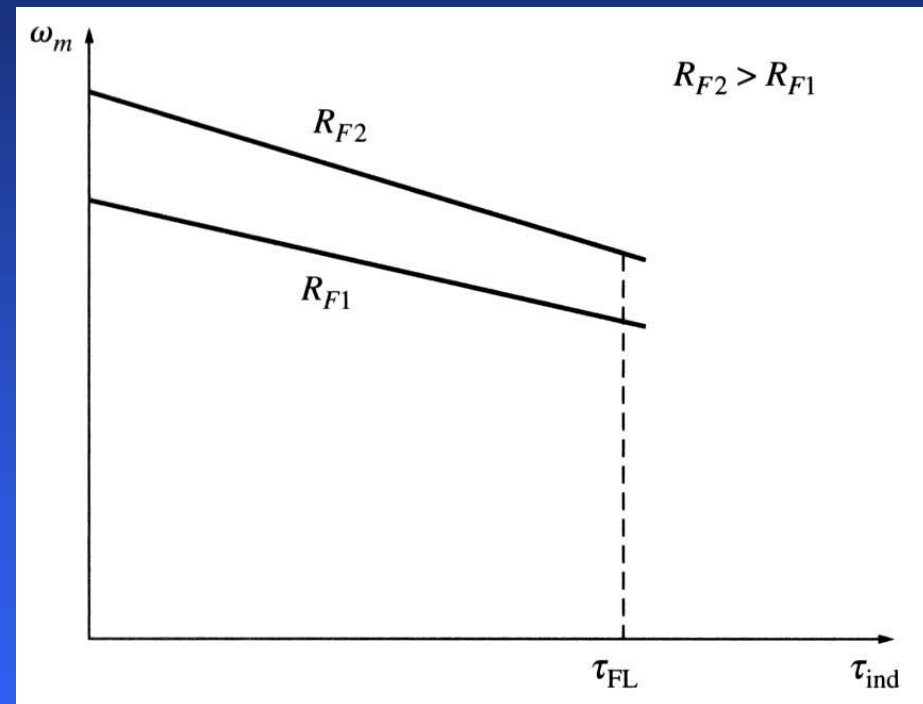

Shunt motor: Speed control

The effect of increasing the field resistance with over an entire load range: from no-load to stall.

At very slow speeds (overloaded motor), an increase in the field resistance decreases the speed. In this region, the increase in armature current is no longer large enough to compensate for the decrease in flux.

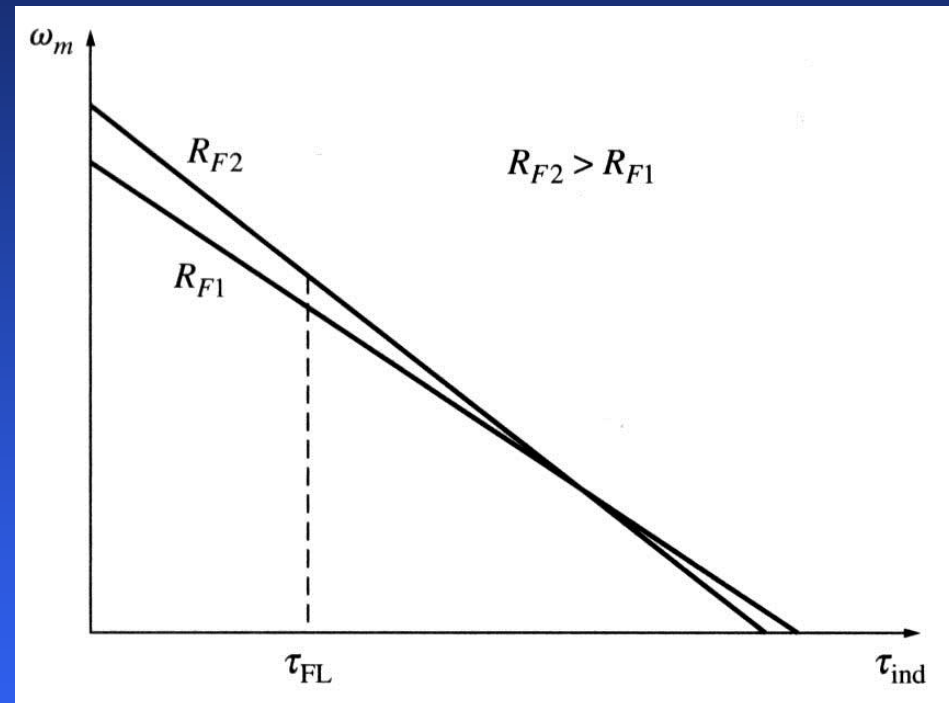

Some small DC motors used in control circuits may operate at speeds close to stall conditions. For such motors, an increase in field resistance may have no effect (or opposite to the expected effect) on the motor speed. The result of speed control by field resistance is not predictable and, thus, this type of control is not very common.

Shunt motor: Speed control

2. Changing the armature voltage

This method implies changing the voltage applied to the armature of the motor without changing the voltage applied to its field. Therefore, the motor must be separately excited to use armature voltage control.

Armature
voltage speed
control

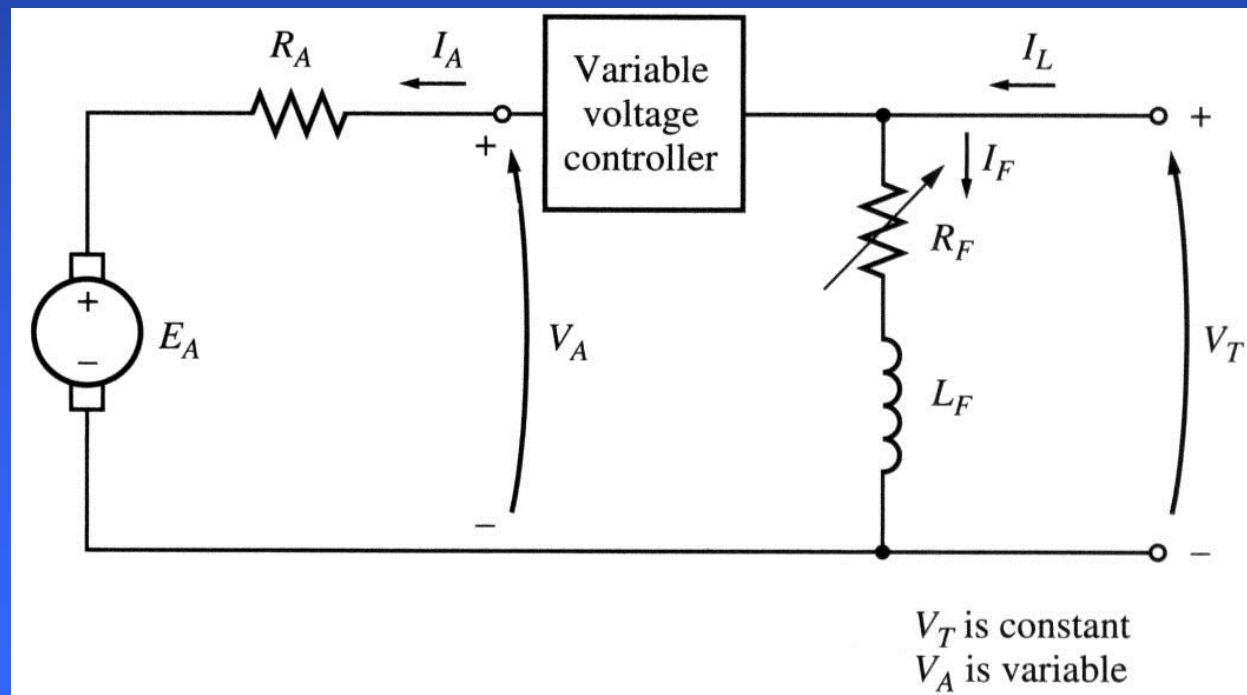

Shunt motor: Speed control

- 1) Increasing the armature voltage V_A increases the armature current ($I_A = (V_A - E_A)/R_A$);
- 2) Increasing armature current I_A increases the induced torque τ_{ind} ($\tau_{ind} = K\phi I_A$);
- 3) Increased induced torque τ_{ind} is now larger than the load torque τ_{load} and, therefore, the speed ω ;
- 4) Increasing speed increases the internal generated voltage ($E_A = K\phi\omega$);
- 5) Increasing E_A decreases the armature current I_A ...
- 6) Decreasing I_A decreases the induced torque until $\tau_{ind} = \tau_{load}$ at a higher speed ω .

Increasing the armature voltage of a separately excited DC motor does not change the slope of its torque-speed characteristic.

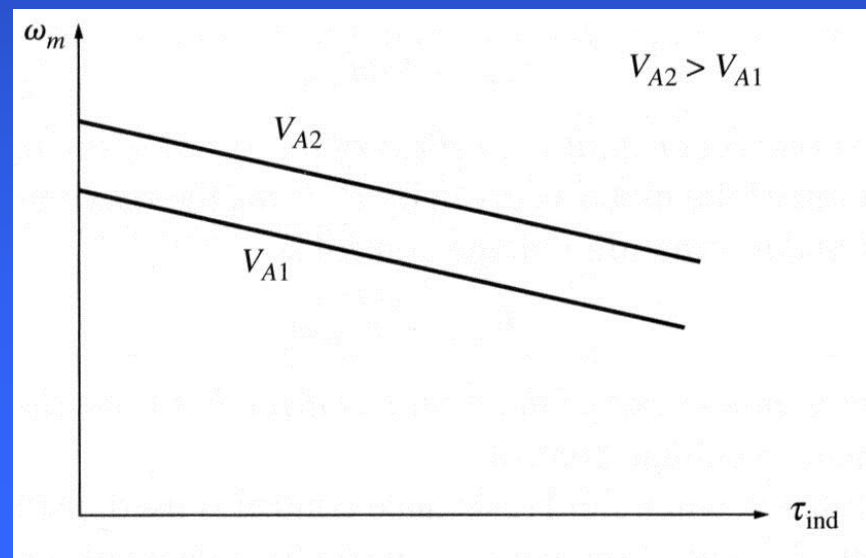

Shunt motor: Speed control

If a motor is operated at its rated terminal voltage, power, and field current, it will be running at the rated speed also called a base speed.

Field resistance control can be used for speeds above the base speed but not below it. Trying to achieve speeds slower than the base speed by the field circuit control, requires large field currents that may damage the field winding.

Since the armature voltage is limited to its rated value, no speeds exceeding the base speed can be achieved safely while using the armature voltage control.

Therefore, armature voltage control can be used to achieve speeds below the base speed, while the field resistance control can be used to achieve speeds above the base speed.

Shunt and separately excited DC motors have excellent speed control characteristic.



Shunt motor: Speed control

For the **armature voltage control**, the flux in the motor is constant. Therefore, the maximum torque in the motor will be constant too regardless the motor speed:

$$\tau_{\max} = K\phi I_{A,\max} \quad (5.64.1)$$

Since the maximum power of the motor is

$$P_{\max} = \tau_{\max} \omega \quad (5.64.2)$$

The maximum power out of the motor is directly proportional to its speed.

For the **field resistance control**, the maximum power out of a DC motor is constant, while the maximum torque is reciprocal to the motor speed.



Shunt motor: Speed control

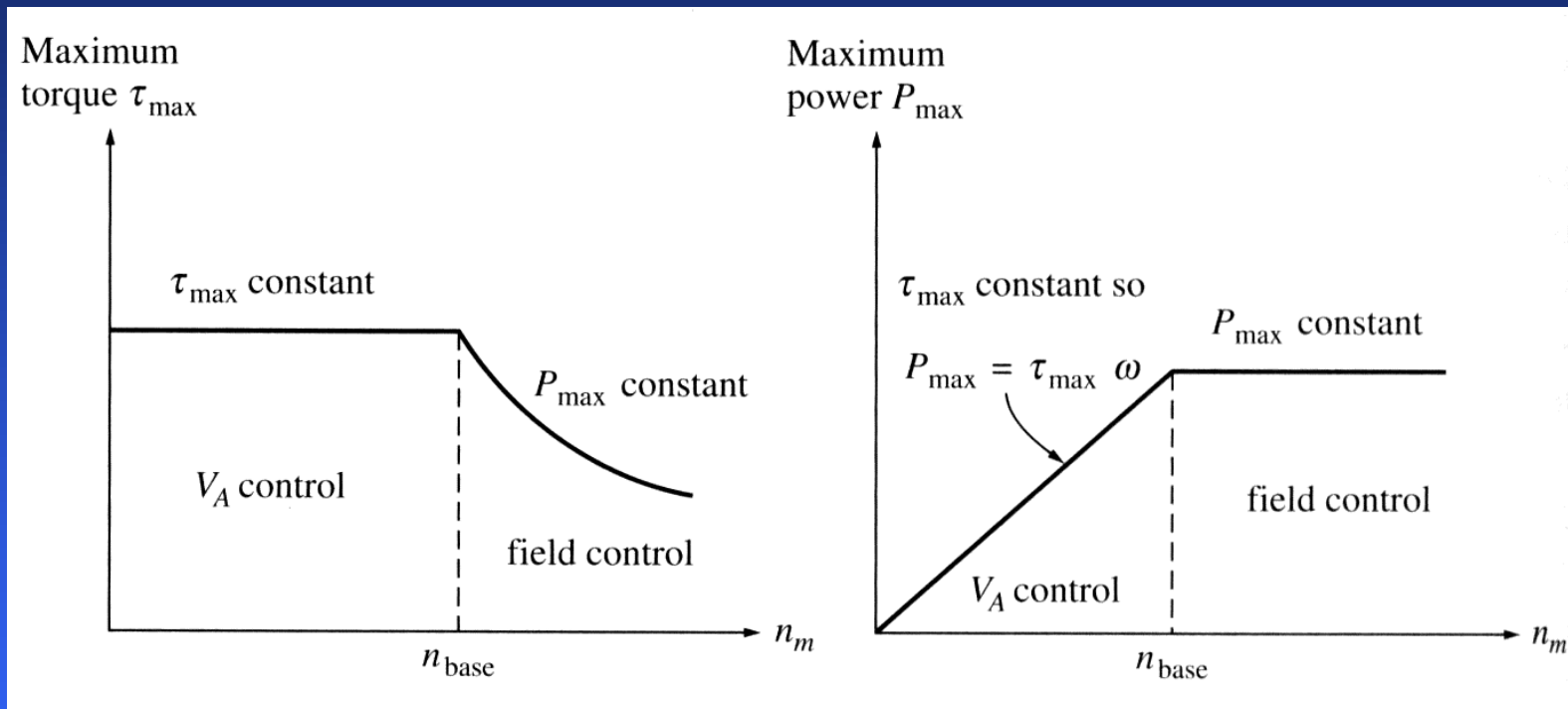

Torque and power limits as functions of motor speed for a shunt (or separately excited) DC motor.

Shunt motor: Speed control: Ex

Example 5.3: A 100 hp, 250 V, 1200 rpm DC shunt motor with an armature resistance of 0.03Ω and a field resistance of 41.67Ω . The motor has compensating windings, so armature reactance can be ignored. Mechanical and core losses may be ignored also. The motor is driving a load with a line current of 126 A and an initial speed of 1103 rpm. Assuming that the armature current is constant and the magnetization curve is

- What is the motor speed if the field resistance is increased to 50Ω ?
- Calculate the motor speed as a function of the field resistance, assuming a constant-current load.
- Assuming that the motor next is connected as a separately excited and is initially running with $V_A = 250 \text{ V}$, $I_A = 120 \text{ A}$ and at $n = 1103 \text{ rpm}$ while supplying a constant-torque load, estimate the motor speed if V_A is reduced to 200 V .

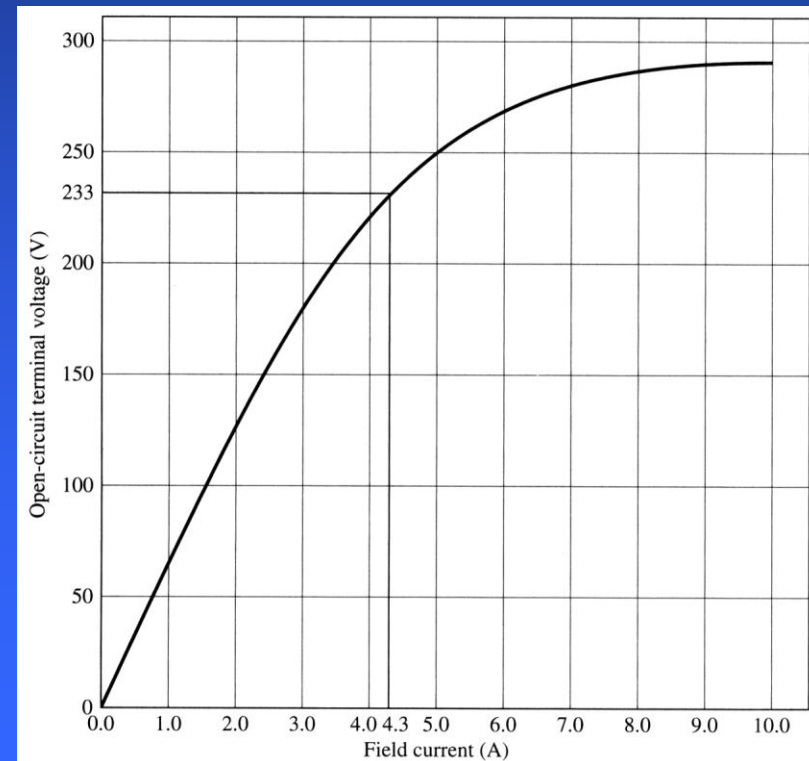

Shunt motor: Speed control: Ex

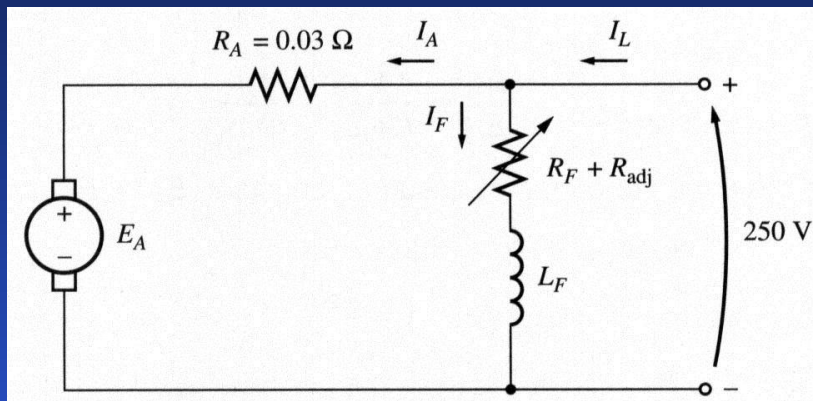

shunt

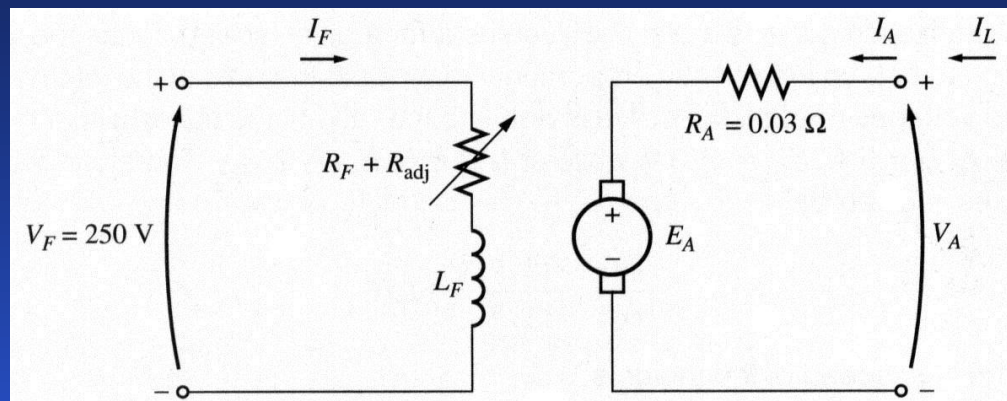

separately-excited

For the given initial line current of 126 A, the initial armature current will be

$$I_{A1} = I_{L1} - I_{F1} = 126 - \frac{250}{41.67} = 120 \text{ A}$$

Therefore, the initial generated voltage for the shunt motor will be

$$E_{A1} = V_T - I_{A1} R_A = 250 - 120 \cdot 0.03 = 246.4 \text{ V}$$

Shunt motor: Speed control: Ex

After the field resistance is increased to 50Ω , the new field current will be

$$I_{F2} = \frac{250}{50} = 5 \text{ A}$$

The ratio of the two internal generated voltages is

$$\frac{E_{A2}}{E_{A1}} = \frac{K\phi_2\omega_2}{K\phi_1\omega_1} = \frac{\phi_2 n_2}{\phi_1 n_1}$$

Since the armature current is assumed constant, $E_{A1} = E_{A2}$ and, therefore

$$n_2 = \frac{\phi_1 n_1}{\phi_2}$$

The values of E_A on the magnetization curve are directly proportional to the flux. Therefore, the ratio of internal generated voltages equals to the ratio of the fluxes within the machine. From the magnetization curve, at $I_F = 5\text{A}$, $E_{A1} = 250\text{V}$, and at $I_F = 6\text{A}$, $E_{A1} = 268\text{V}$. Thus:



Shunt motor: Speed control: Ex

$$n_2 = \frac{\phi_1 n_1}{\phi_2} = \frac{E_{A1} n_1}{E_{A2}} = \frac{268}{250} 1103 = 1187 \text{ rpm}$$

b) A speed vs. R_F characteristic is shown below:

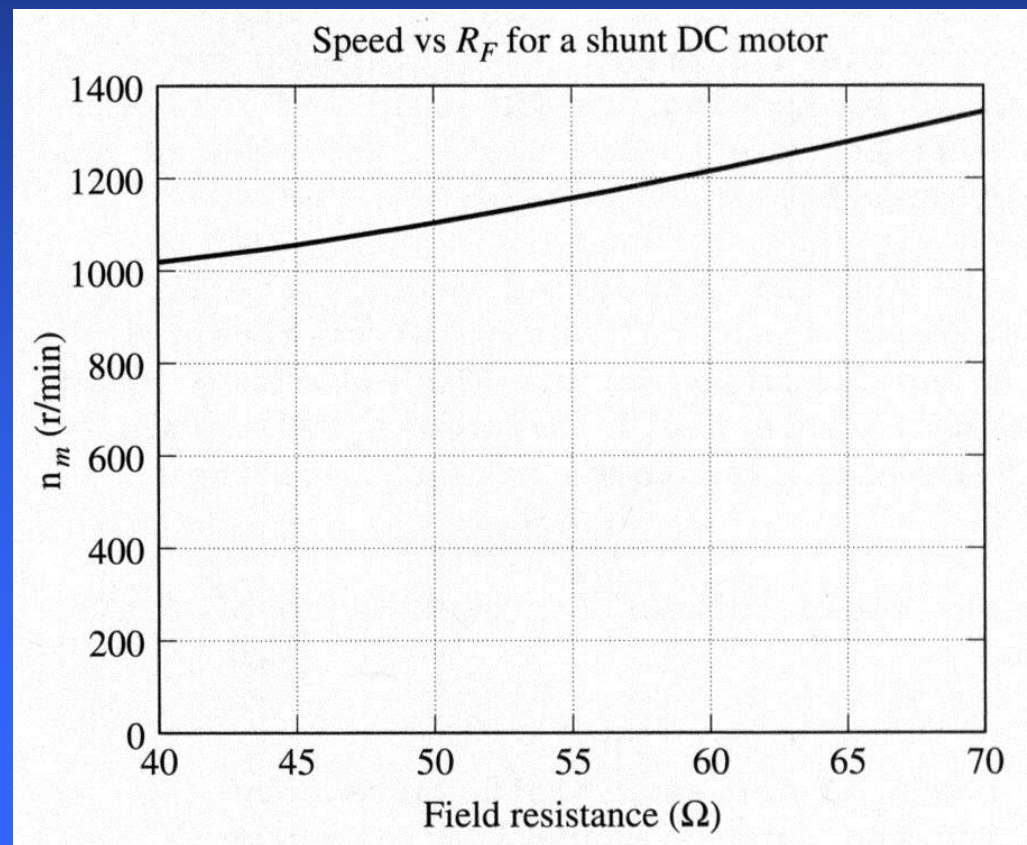

Shunt motor: Speed control: Ex

c) For a separately excited motor, the initial generated voltage is

$$E_{A1} = V_{T1} - I_{A1}R_A$$

Since

$$\frac{E_{A2}}{E_{A1}} = \frac{K\phi_2\omega_2}{K\phi_1\omega_1} = \frac{\phi_2 n_2}{\phi_1 n_1}$$

and since the flux ϕ is constant $n_2 = \frac{E_{A2}n_1}{E_{A1}}$

Since the both the torque and the flux are constants, the armature current I_A is also constant. Then

$$n_2 = \frac{V_{T2} - I_{A2}R_A}{V_{T1} - I_{A1}R_A} n_1 = \frac{200 - 120 \cdot 0.03}{250 - 120 \cdot 0.03} 1103 = 879 \text{ rpm}$$

Shunt motor: The effect of an open field circuit

If the field circuit is left open on a shunt motor, its field resistance will be infinite. Infinite field resistance will cause a drastic flux drop and, therefore, a drastic drop in the generated voltage. The armature current will be increased enormously increasing the motor speed.

A similar effect can be caused by armature reaction. If the armature reaction is severe enough, an increase in load can weaken the flux causing increasing the motor speed. An increasing motor speed increases its load, which increases the armature reaction weakening the flux again. This process continues until the motor overspeeds. This condition is called runaway.



Motor types: The permanent-magnet DC motor

A permanent magnet DC (PMDC) motor is a motor whose poles are made out of permanent magnets.

Advantages:

1. Since no external field circuit is needed, there are no field circuit copper losses;
2. Since no field windings are needed, these motors can be considerable smaller.

Disadvantages:

1. Since permanent magnets produces weaker flux densities than externally supported shunt fields, such motors have lower induced torque.
2. There is always a risk of demagnetization from extensive heating or from armature reaction effects (via armature mmf).



Motor types: The permanent-magnet DC motor

Normally (for cores), a ferromagnetic material is selected with small residual flux B_{res} and small coercive magnetizing intensity H_C .

However, a maximally large residual flux B_{res} and large coercive magnetizing intensity H_C are desirable for permanent magnets forming the poles of PMDC motors...

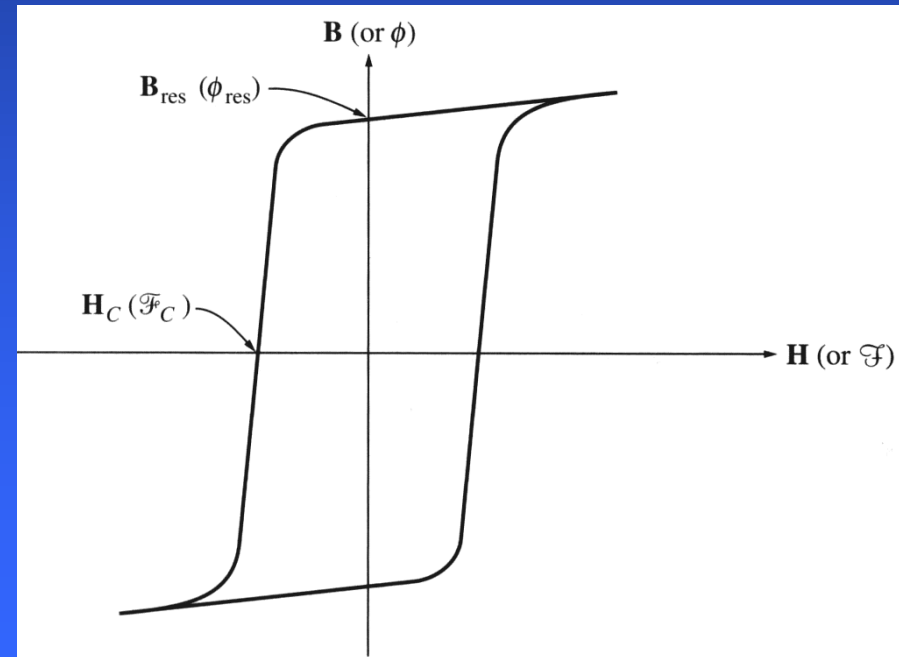
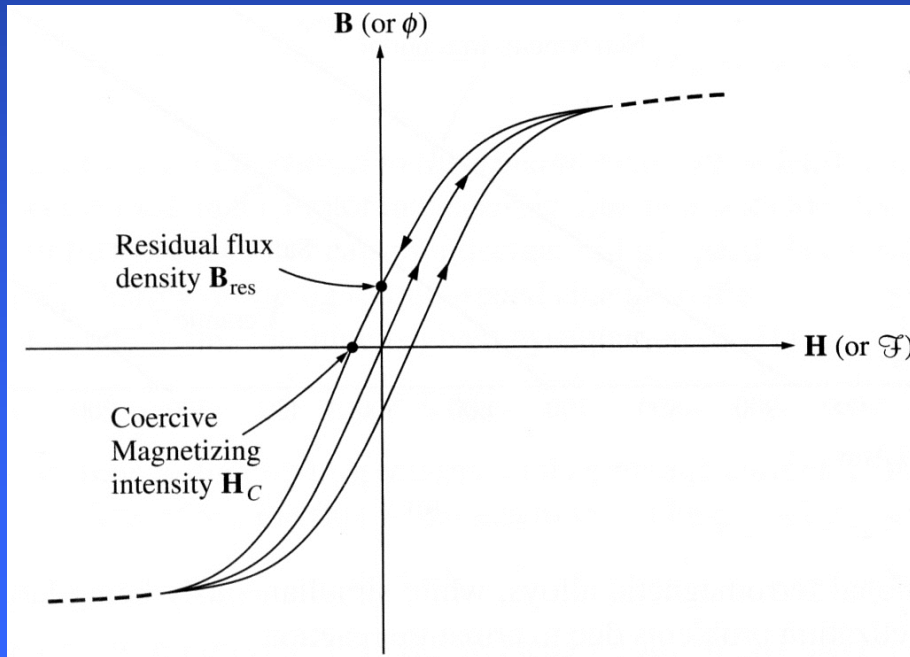

Motor types: The permanent-magnet DC motor

A comparison of magnetization curves of newly developed permanent magnets with that of a conventional ferromagnetic alloy (Alnico 5) shows that magnets made of such materials can produce the same residual flux as the best ferromagnetic cores.

Design of permanent-magnet DC motors is quite similar to the design of shunt motors, except that the flux of a PMDC motor is fixed. Therefore, the only method of speed control available for PMDC motors is armature voltage control.

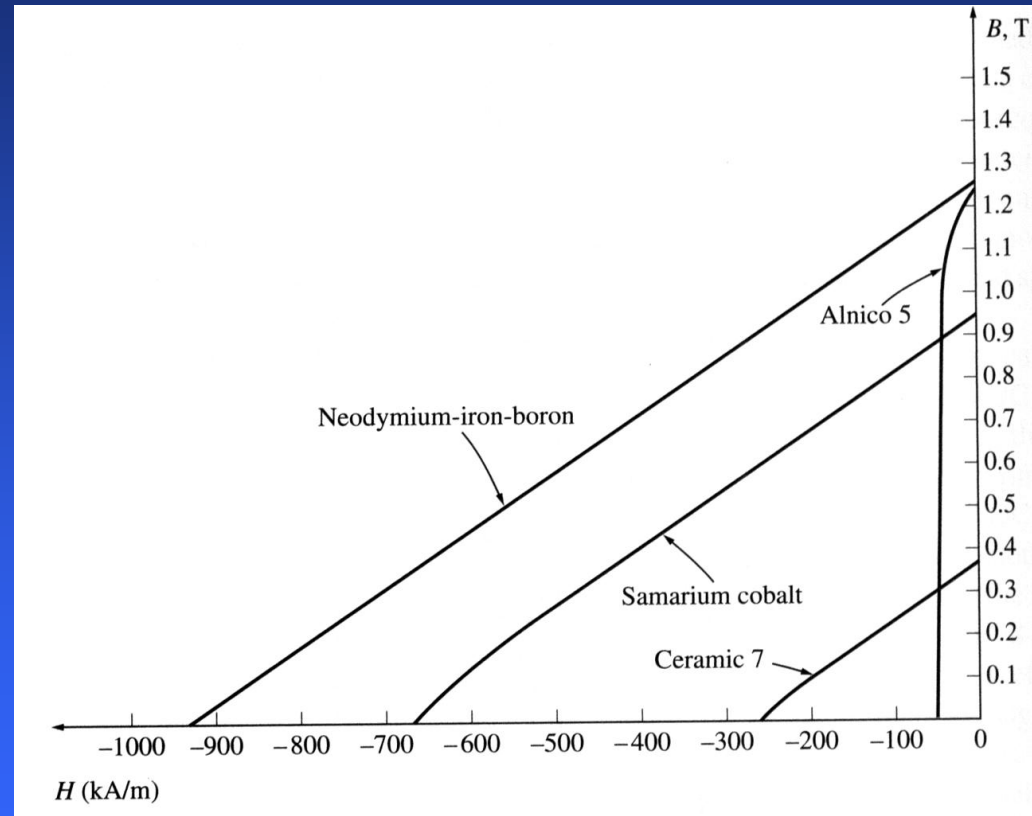

Motor types: The series DC motor

A series DC motor is a DC motor whose field windings consists of a relatively few turns connected in series with armature circuit. Therefore:

$$V_T = E_A + I_A (R_A + R_S) \quad (5.75.1)$$

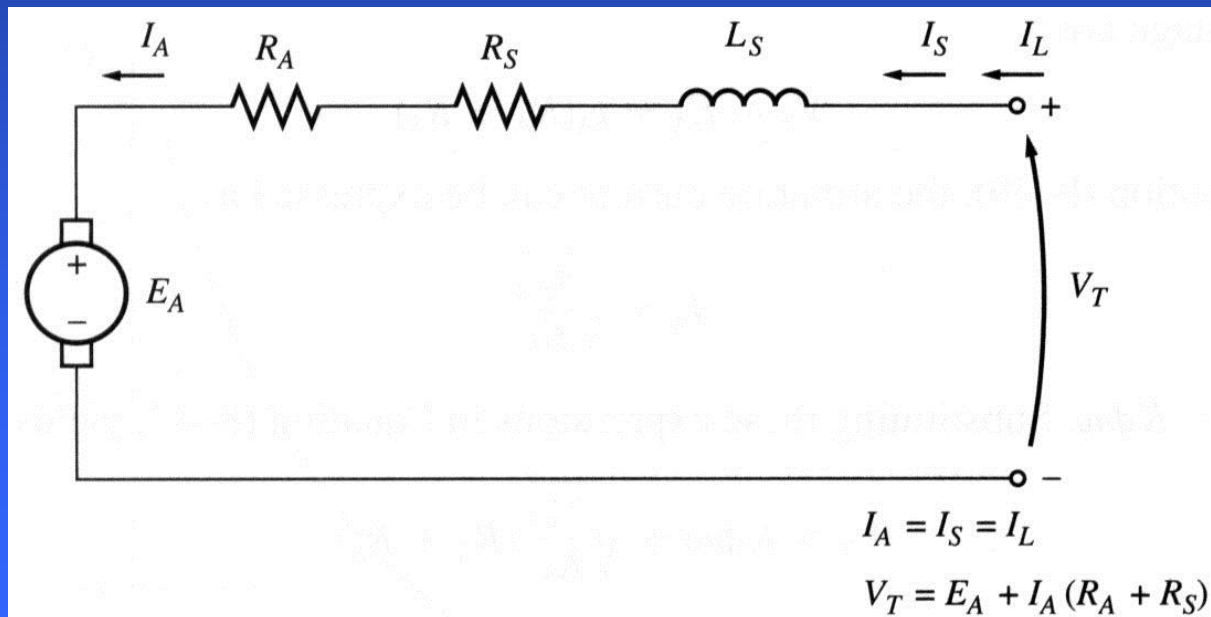

Series motor: induced torque

The terminal characteristic of a series DC motor is quite different from that of the shunt motor since the flux is directly proportional to the armature current (assuming no saturation). An increase in motor flux causes a decrease in its speed; therefore, a series motor has a dropping torque-speed characteristic.

The induced torque in a series machine is

$$\tau_{ind} = K\phi I_A \quad (5.76.1)$$

Since the flux is proportional to the armature current:

$$\phi = cI_A \quad (5.76.2)$$

where c is a proportionality constant. Therefore, the torque is

$$\tau_{ind} = KcI_A^2 \quad (5.76.3)$$

Torque in the motor is proportional to the square of its armature current. **Series motors supply the highest torque among the DC motors. Therefore, they are used as car starter motors, elevator motors etc.**



Series motor: terminal characteristic

Assuming first that the magnetization curve is linear and no saturation occurs, flux is proportional to the armature current:

$$\phi = cI_A \quad (5.77.1)$$

Since the armature current is

$$I_A = \sqrt{\frac{\tau_{ind}}{Kc}} \quad (5.77.2)$$

and the armature voltage

$$E_A = K\phi\omega \quad (5.77.3)$$

The Kirchhoff's voltage law would be

$$V_T = E_A + I_A(R_A + R_S) = K\phi\omega + \sqrt{\frac{\tau_{ind}}{Kc}}(R_A + R_S) \quad (5.77.4)$$

Since (5.77.1), the torque: $\tau_{ind} = KcI_A^2 = \frac{K}{c}\phi^2$ (5.77.5)

Series motor: terminal characteristic

Therefore, the flux in the motor is

$$\phi = \sqrt{\frac{c}{K}} \sqrt{\tau_{ind}} \quad (5.78.1)$$

The voltage equation (5.77.4) then becomes

$$V_T = K \sqrt{\frac{c}{K}} \sqrt{\tau_{ind}} \omega + \sqrt{\frac{\tau_{ind}}{Kc}} (R_A + R_S) \quad (5.78.2)$$

which can be solved for the speed:

$$\omega = \frac{V_T}{\sqrt{Kc}} \frac{1}{\sqrt{\tau_{ind}}} - \frac{R_A + R_S}{Kc} \quad (5.78.3)$$

The speed of unsaturated series motor inversely proportional to the square root of its torque.

Series motor: terminal characteristic

One serious disadvantage of a series motor is that its speed goes to infinity for a zero torque.

In practice, however, torque never goes to zero because of the mechanical, core, and stray losses. Still, if no other loads are attached, the motor will be running fast enough to cause damage.

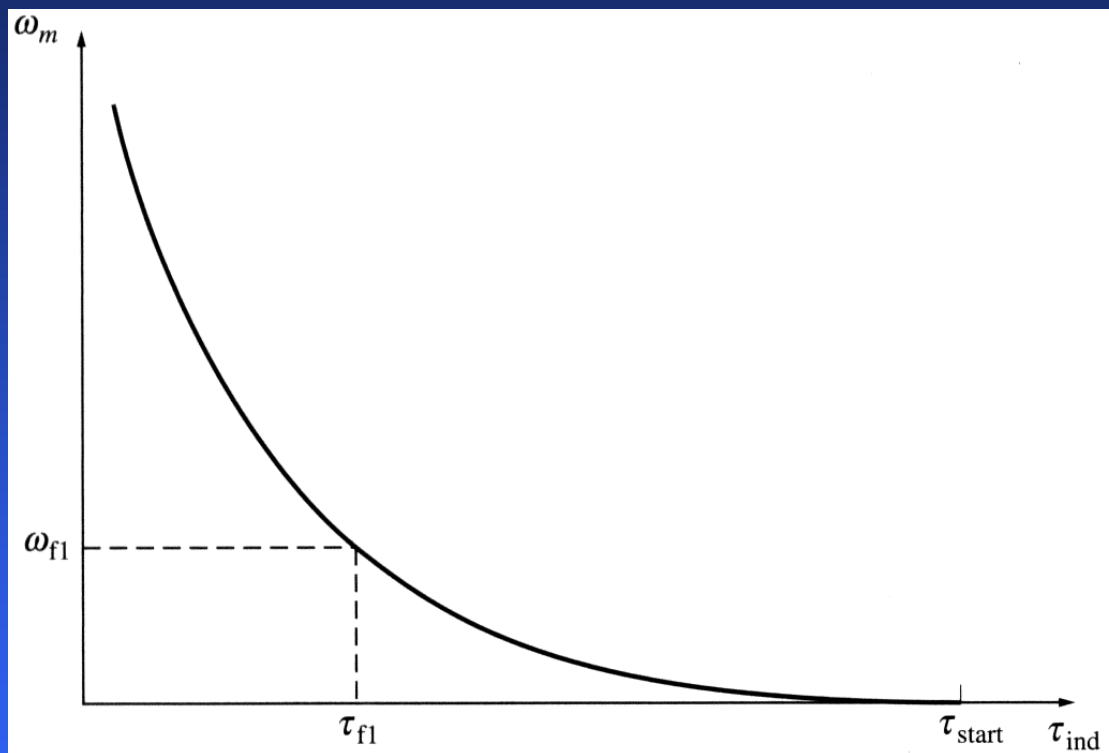

Steps must be taken to ensure that a series motor **always** has a load! Therefore, it is not a good idea to connect such motors to loads by a belt or other mechanism that could break.

Series motor: terminal characteristic – Example

Example 5.4: A 250 V series DC motor with compensating windings has a total series resistance $R_A + R_S$ of 0.08Ω . The series field consists of 25 turns per pole and the magnetization curve is

- Find the speed and induced torque of this motor when its armature current is 50 A.
- Calculate and plot its torque-speed characteristic.

a) To analyze the behavior of a series motor with saturation, we pick points along the operating curve and find the torque and speed for each point. Since the magnetization curve is given in units of mmf (ampere-turns) vs. E_A for a speed of 1200 rpm, calculated values of E_A must be compared to equivalent values at 1200 rpm.

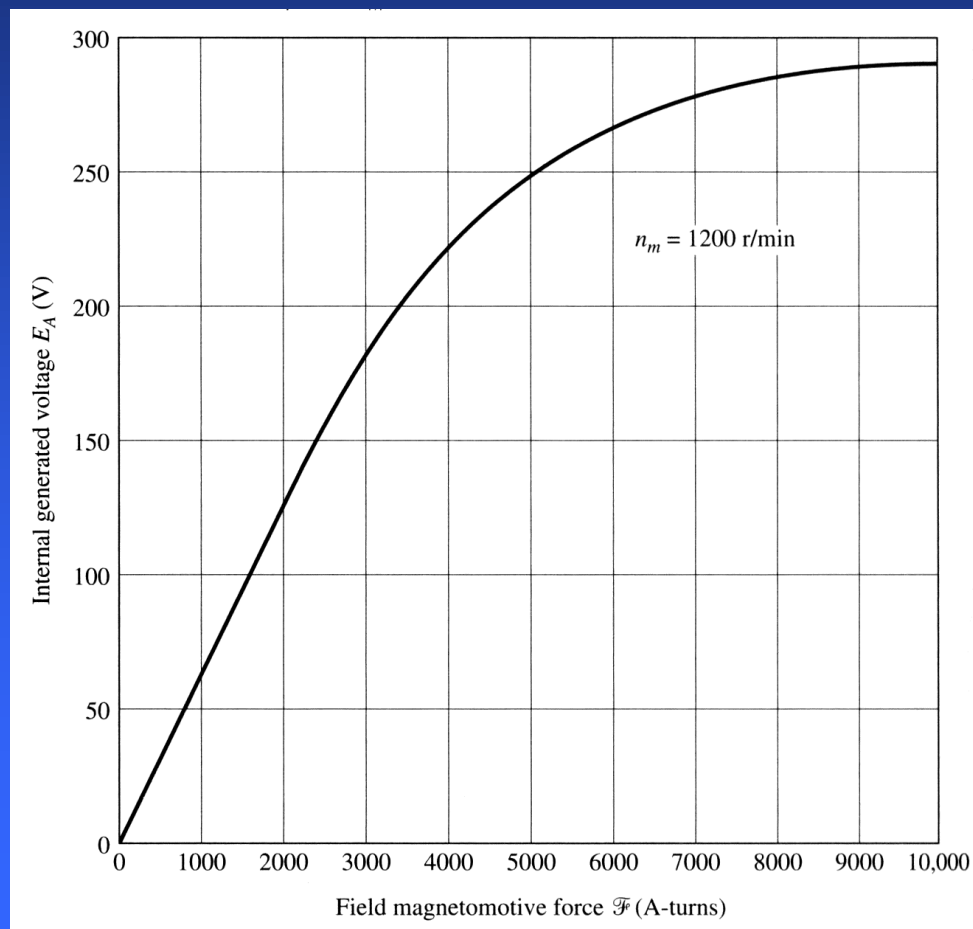

Series motor: terminal characteristic – Example

For $I_A = 50$ A

$$E_A = V_T - I_A(R_A + R_S) = 250 - 50 \cdot 0.08 = 246 \text{ V}$$

Since for a series motor $I_A = I_F = 50$ A, the mmf is

$$F = NI = 25 \cdot 50 = 1250 \text{ A-turns}$$

From the magnetization curve, at this mmf, the internal generated voltage is $E_{A0} = 80$ V. Since the motor has compensating windings, the correct speed of the motor will be

$$n = \frac{E_A}{E_{A0}} n_0 = \frac{246}{80} 1200 = 3690 \text{ rpm}$$

The resulting torque: $\tau_{ind} = \frac{E_A I_A}{\omega} = \frac{246 \cdot 50}{3690 \cdot 2\pi/60} = 31.8 \text{ N-m}$

Series motor: terminal characteristic – Example

b) The complete torque-speed characteristic

We notice severe over-speeding at low torque values.

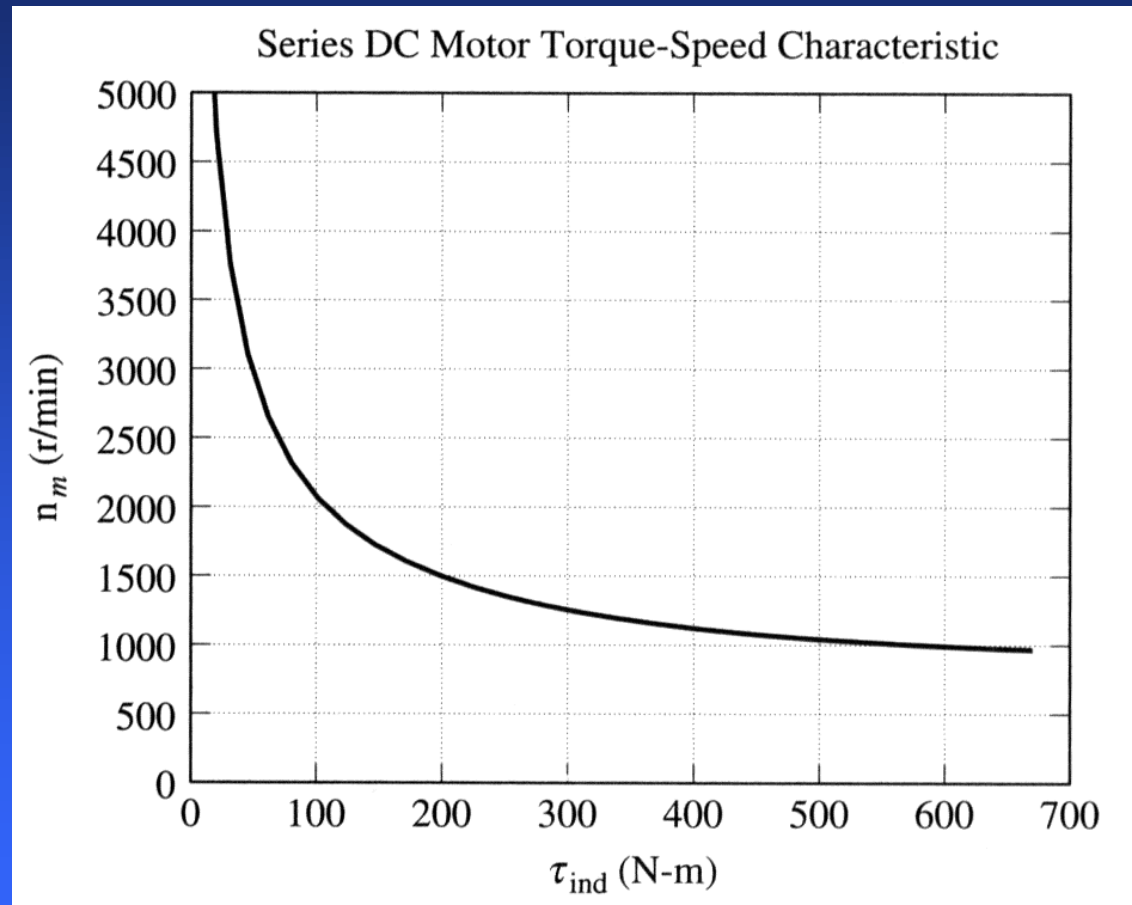

Series motor: Speed control

The only way to control speed of a series DC motor is by changing its terminal voltage, since the motor speed is directly proportional to its terminal voltage ***for any given torque.***

Motor types: **Compounded DC motor**

A compounded DC motor is a motor with both a shunt and a series field.

Current flowing into a dotted end of a coil (shunt or series) produces a positive mmf.

If current flows into the dotted ends of both coils, the resulting mmfs add to produce a larger total mmf – cumulative compounding.

If current flows into the dotted end of one coil and out of the dotted end of another coil, the resulting mmfs subtract – differential compounding.

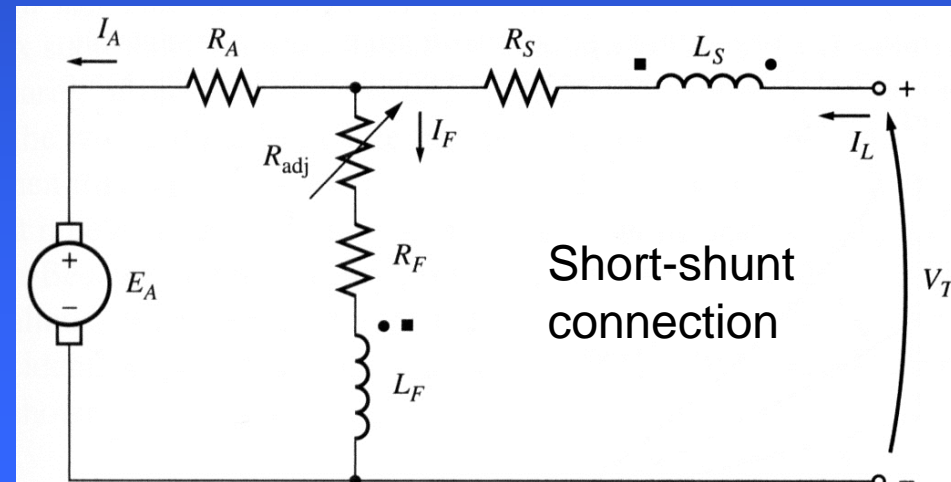
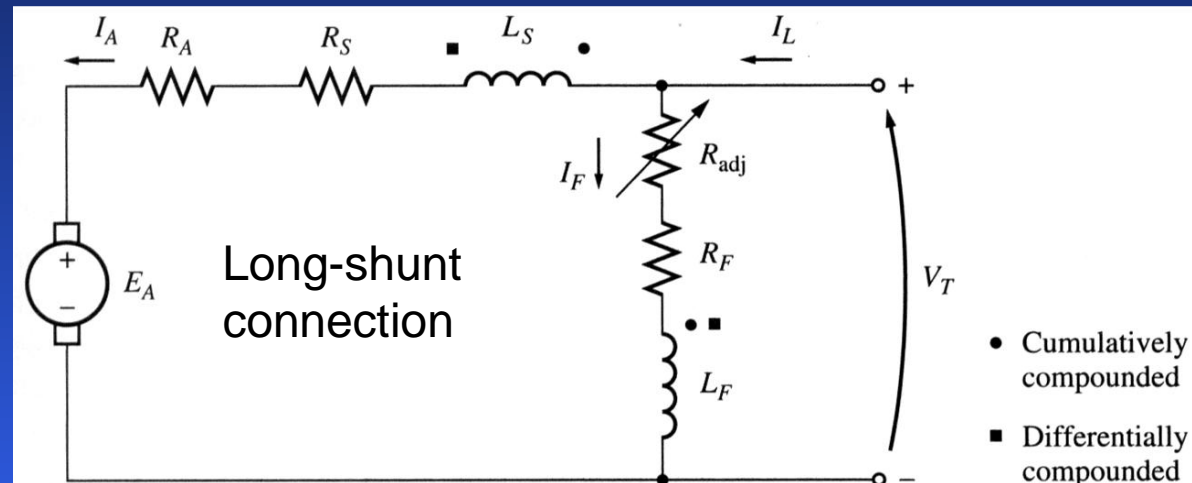

Motor types: Compounded DC motor

The Kirchhoff's voltage law equation for a compounded DC motor is

$$V_T = E_A + I_A (R_A + R_S) \quad (5.85.1)$$

The currents in a compounded DC motor are

$$I_A = I_L - I_F \quad (5.85.2)$$

$$I_F = \frac{V_T}{R_F} \quad (5.85.3)$$

The mmf of a compounded DC motor: Cumulatively compounded

$$F_{net} = F_F \pm F_{SE} - F_{AR} \quad (5.85.4)$$

Differentially compounded

The effective shunt field current in a compounded DC motor:

$$I_F^* = I_F + \frac{N_{SE}}{N_F} I_A - \frac{F_{AR}}{N_F} \quad (5.85.5)$$

Number of turns

Cumulatively compounded motors: torque-speed characteristic

In a cumulatively compounded motor, there is a constant component of flux and a component proportional to the armature current (and thus to the load). These motors have a higher starting torque than shunt motors (whose flux is constant) but lower than series motors (whose flux is proportional to the armature current).

The series field has a small effect at light loads – the motor behaves as a shunt motor. The series flux becomes quite large at large loads – the motor acts like a series motor.

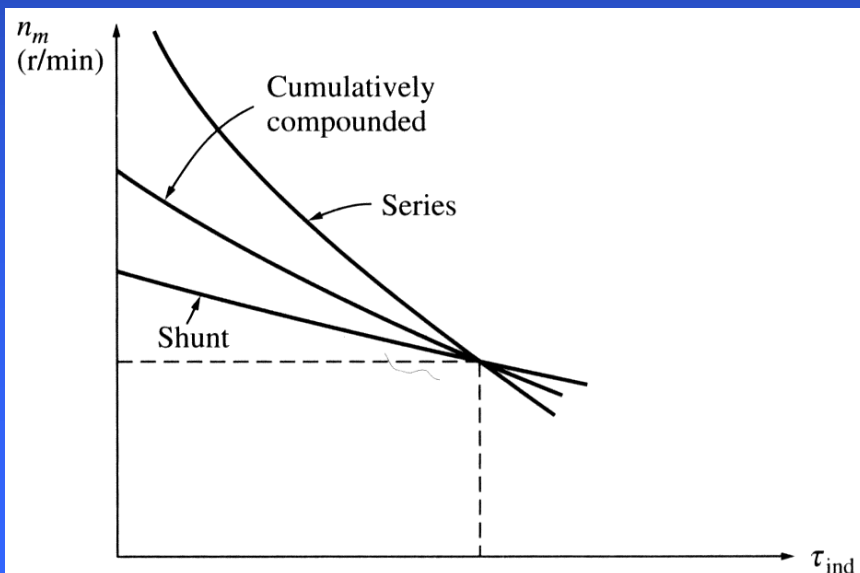

Similar (to the previously discussed) approach is used for nonlinear analysis of compounded motors.

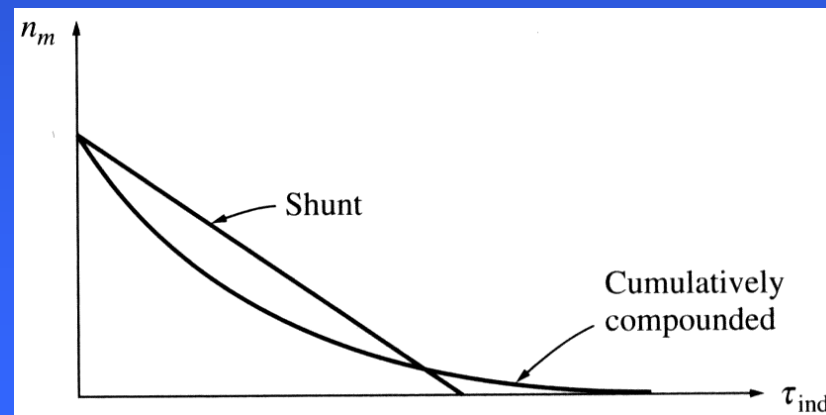

Differentially compounded motors: torque-speed characteristic

Since the shunt mmf and series mmf subtract from each other in a differentially compounded motor, increasing load increases the armature current I_A and decreases the flux. When flux decreases, the motor speed increases further increasing the load. This results in an instability (much worse than one of a shunt motor) making differentially compounded motors unusable for any applications.

In addition to that, these motors are not easy to start... The motor typically remains still or turns very slowly consuming enormously high armature current.

Stability problems and huge starting armature current lead to these motors being never used **intentionally**.

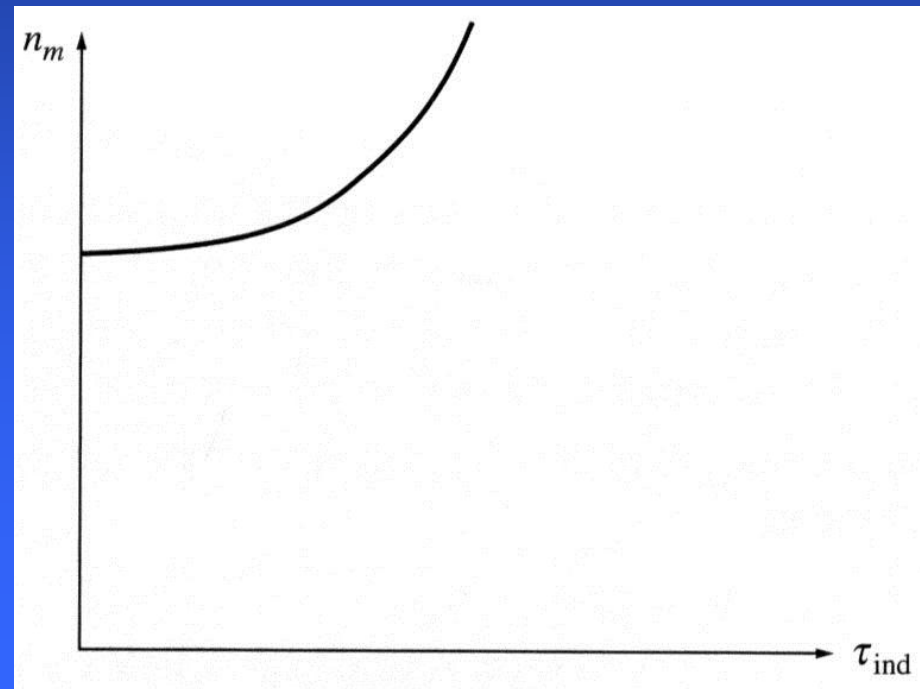

Compounded DC motor: Example

Example 5.5: A 100 hp, 250 V compounded DC motor with compensating windings has an internal resistance, including the series winding of 0.04Ω . There are 1000 turns per pole on the shunt field and 3 turns per pole on the series windings. The magnetization curve is shown below.

The field resistor has been adjusted for the motor speed of 1200 rpm. The mechanical, core, and stray losses may be neglected.

- a) Find the no-load shunt field current.
Find the speed at $I_A = 200$ A if the motor is b) cumulatively; c) differentially compounded

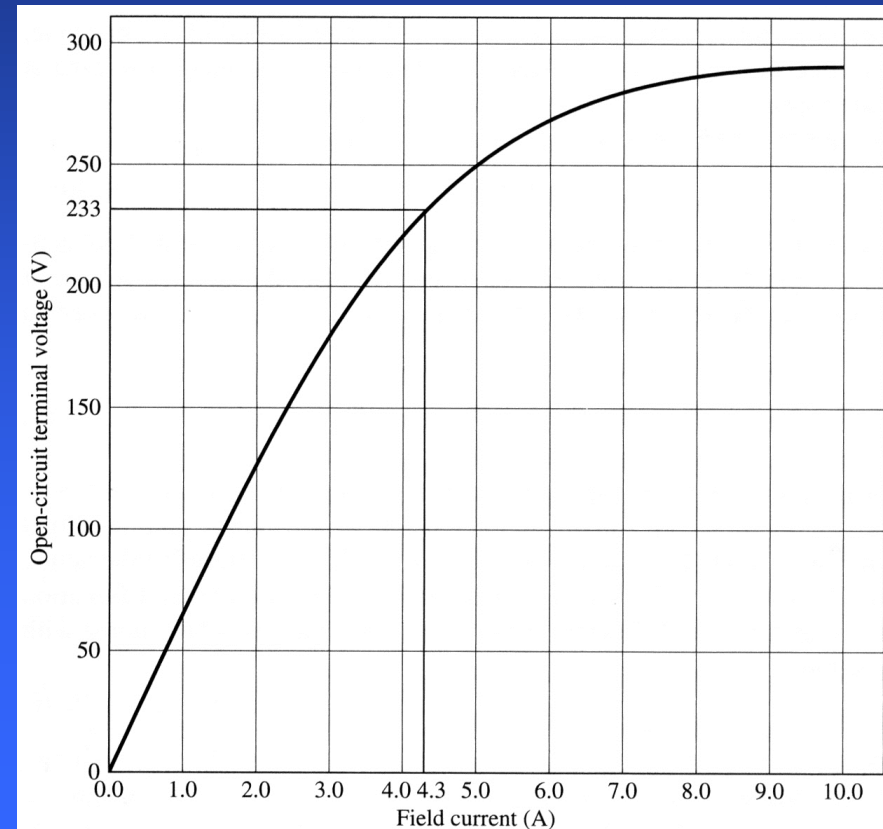
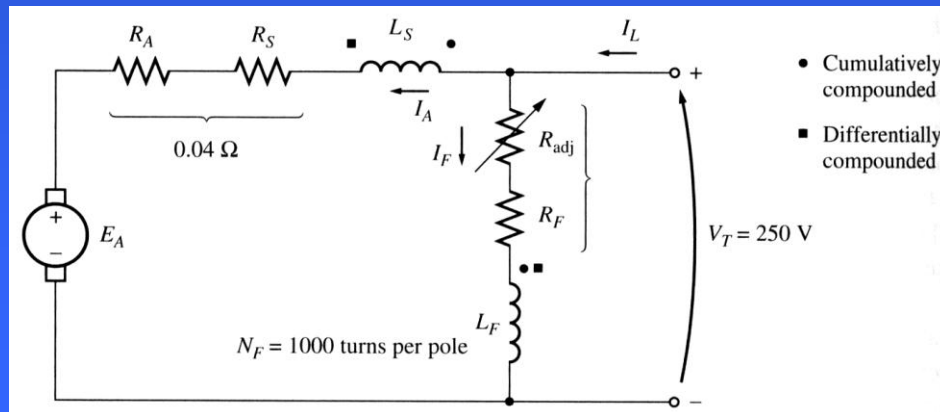

Compounded DC motor: Example

- a) At no load, the armature current is zero; therefore, the internal generated voltage equals $V_T = 250$ V. From the magnetization curve, a field current of 5 A will produce a voltage $E_A = 250$ V at 1200 rpm. Therefore, the shunt field current is 5 A.
- b) When the armature current is 200 A, the internal generated voltage is

$$E_A = V_T - I_A(R_A + R_S) = 250 - 200 \cdot 0.04 = 242 \text{ V}$$

The effective field current of a cumulatively compounded motor will be

$$I_F^* = I_F + \frac{N_{SE}}{N_F} I_A - \frac{F_{AR}}{N_F} = 5 + \frac{3}{1000} 200 = 5.6 \text{ A}$$

From the magnetization curve, $E_{A0} = 262$ V at speed $n_0 = 1200$ rpm. The actual motor speed is

$$n = \frac{E_A}{E_{A0}} n_0 = \frac{242}{262} 1200 = 1108 \text{ rpm}$$



Compounded DC motor: Example

c) The effective field current of a differentially compounded motor will be

$$I_F^* = I_F - \frac{N_{SE}}{N_F} I_A - \frac{F_{AR}}{N_F} = 5 - \frac{3}{1000} 200 = 4.4 \text{ A}$$

From the magnetization curve, $E_{A0} = 236 \text{ V}$ at speed $n_0 = 1200 \text{ rpm}$. The actual motor speed is

$$n = \frac{E_A}{E_{A0}} n_0 = \frac{242}{236} 1200 = 1230 \text{ rpm}$$

Cumulatively compounded motors: speed control

The same two techniques that have been discussed for a shunt motor are also available for speed control of a cumulatively compounded motor.

1. Adjusting the field resistance R_F ;
2. Adjusting the armature voltage V_A .

The details of these methods are very similar to already discussed for shunt DC motors.



DC motor starters

In order for DC motors to function properly, they must have some special control and protection equipment associated with them. The purposes of this equipment are:

1. To protect the motor against damage due to short circuits in the equipment;
2. To protect the motor against damage from long-term overloads;
3. To protect the motor against damage from excessive starting currents;
4. To provide a convenient manner in which to control the operating speed of the motor.



DC motor problems on starting

At starting conditions, the motor is not turning, therefore the internal generated voltage $E_A = 0V$. Since the internal resistance of a normal DC motor is very low (3-6 % pu), a very high current flows.

For instance, for a 50 hp, 250 V DC motor with armature resistance R_A of 0.06Ω and a full-load current about 200 A, the starting current is

$$I_A = \frac{V_T - E_A}{R_A} = \frac{250 - 0}{0.06} = 4167 \text{ A}$$

This current is over 20 times the motor's rated full-load current and may severely damage the motor.

A solution to the problem of excessive starting current is to insert a starting resistor in series with the armature to limit the current until E_A can build up to limit the armature current. However, this resistor must be removed from the circuit as the motor speed is high since otherwise such resistor would cause losses and would decrease the motor's torque-speed characteristic.



DC motor problems on starting

In practice, a starting resistor is made up of a series of resistors that can be successively removed from the circuit as the motor speeds up.

A shunt motor with an extra starting resistor that can be cut out of the circuit in segments by closing the 1A, 2A, and 3A contacts.

Therefore, two considerations are needed to be taken into account: Select the values and the number of resistor segments needed to limit the starting current to desired ranges;

Design a control circuit shutting the resistor bypass contacts at the proper time to remove particular parts of the resistor from the circuit.

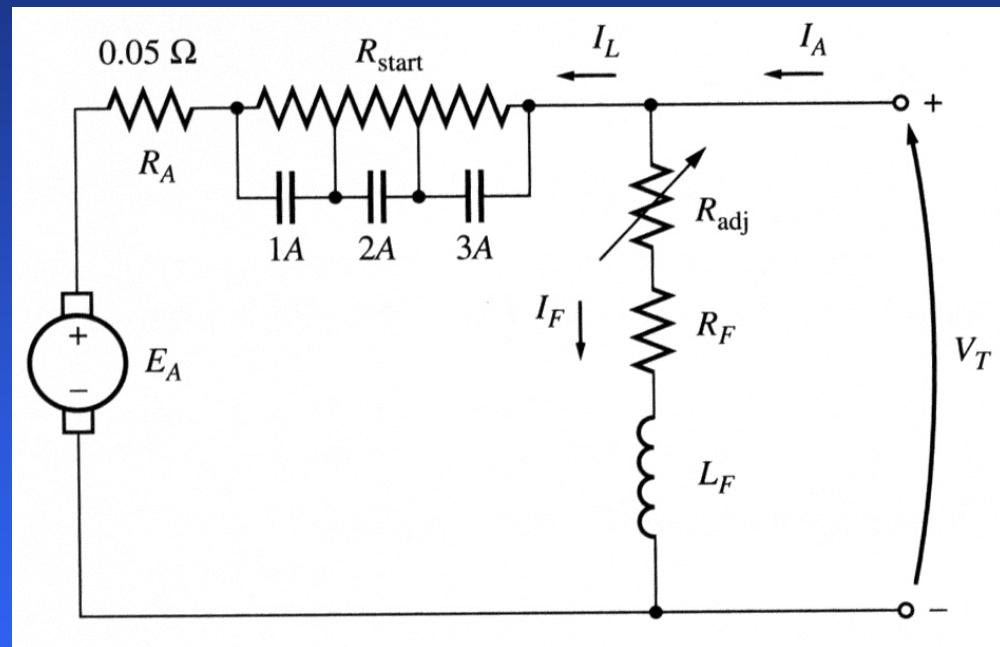

DC motor problems on starting: Ex

Example 5.6: A 100 hp, 250 V 350 A shunt DC motor with an armature resistance of 0.05Ω needs a starter circuit that will limit the max starting current to twice its rated value and which will switch out sections of resistor once the armature current decreases to its rated value.

- How many stages of starting resistance will be required to limit the current to the specified range?
- What must the value of each segment of the resistor to be? At what voltage should each stage of the starting resistance be cut out?

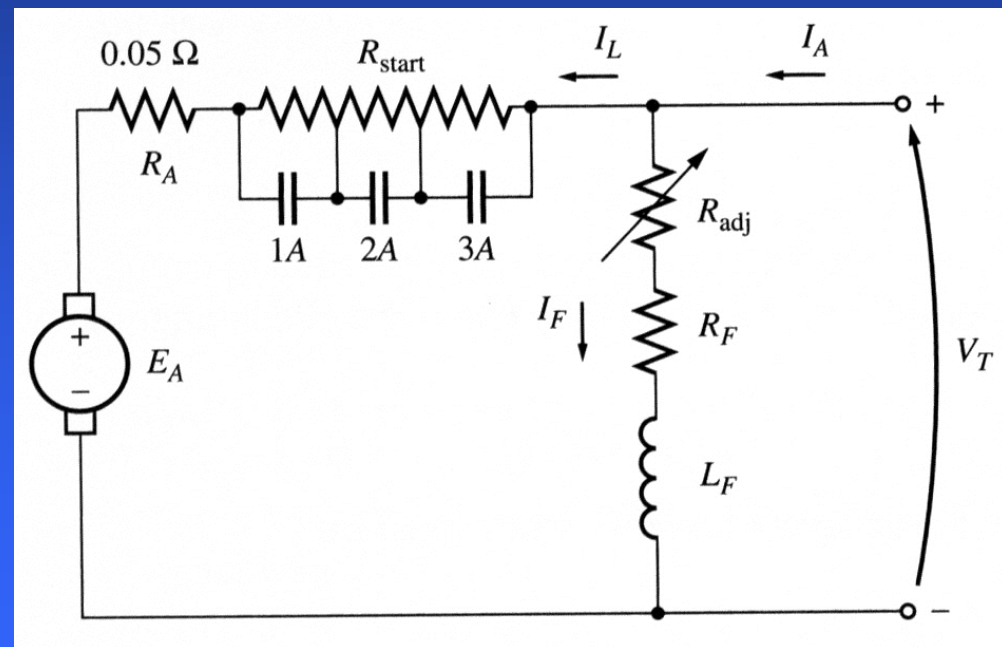

DC motor problems on starting: Ex

a. The starting resistor must be selected such that the current flow at the start equals twice the rated current. As the motor speeds up, an internal voltage E_A (which opposes the terminal voltage of the motor and, therefore, limits the current) is generated. When the current falls to the rated value, a section of the starting resistor needs to be taken out to increase the current twice. This process (of taking out sections of the starting resistor) repeats until the entire starting resistance is removed. At this point, the motor's armature resistance will limit the current to safe values by itself.

The original resistance in the starting circuit is

$$R_{tot} = R_1 + R_2 + \dots + R_A = \frac{V_T}{I_{max}}$$

After the stages 1 through i are shorted out, the total resistance left in the starting circuit is

$$R_{tot,i} = R_{i+1} + \dots + R_A$$

DC motor problems on starting: Ex

The resistance R_1 must be switched out of the circuit when the armature current falls to

$$I_{A,\min} = \frac{V_T - E_{A,1}}{R_{tot}} = I_{\min} = 350 \text{ A}$$

After the resistance R_1 is out of the circuit, the armature current must increase to

$$I_{A,\max} = \frac{V_T - E_{A,2}}{R_{tot,1}} = I_{\max} = 700 \text{ A}$$

Since $E_A = K\phi\omega$, the quantity $V_T - E_A$ must be constant when the resistance is switched out. Therefore

$$I_{\min} R_{tot} = V_T - E_A = I_{\max} R_{tot,1}$$

The resistance left in the circuit is

$$R_{tot,1} = \frac{I_{\min}}{I_{\max}} R_{tot} \Rightarrow R_{tot,n} = \left(\frac{I_{\min}}{I_{\max}} \right)^n R_{tot}$$

DC motor problems on starting: Ex

The starting process is completed when $R_{tot,n}$ is not greater than the internal armature resistance R_A . At the boundary:

$$R_A = R_{tot,n} = \left(\frac{I_{\min}}{I_{\max}} \right)^n R_{tot}$$

Solving for n :

$$n = \frac{\log(R_A/R_{tot})}{\log(I_{\min}/I_{\max})}$$

Notice that the number of stages n must be rounded up to the next integer.

$$R_{tot} = \frac{V_T}{I_{\max}} = \frac{250}{700} = 0.357 \Omega$$

$$n = \frac{\log(R_A/R_{tot})}{\log(I_{\min}/I_{\max})} = \frac{\log(0.05/0.357)}{\log(350/700)} = 2.84 \approx 3$$

DC motor problems on starting: Ex

b. The armature circuit will contain the armature resistance R_A and three starting resistors. At first, $E_A = 0$, $I_A = 700$ A, and the total resistance is 0.357Ω . The total resistance will be in the circuit until the current drops to 350 A. This occurs when

$$E_{A,1} = V_T - I_{A,\min} R_{tot} = 250 - 350 \cdot 0.357 = 125 \text{ V}$$

At this time, the starting resistor R_1 will be taken out making

$$R_{tot,1} = R_A + R_2 + R_3 = \frac{V_T - E_{A,1}}{I_{\max}} = \frac{250 - 125}{700} = 0.1786 \Omega$$

This (new) total resistance will be in the circuit until the current drops again to 350 A. This occurs when

$$E_{A,2} = V_T - I_{A,\min} R_{tot,1} = 250 - 350 \cdot 0.1786 = 187.5 \text{ V}$$

At this time, the starting resistor R_2 will be taken out leaving

$$R_{tot,2} = R_A + R_3 = \frac{V_T - E_{A,2}}{I_{\max}} = \frac{250 - 187.5}{700} = 0.0893 \Omega$$



DC motor problems on starting: Ex

This total resistance will be in the circuit until the current drops again to 350 A. This occurs when

$$E_{A,3} = V_T - I_{A,\min} R_{tot,2} = 250 - 350 \cdot 0.0893 = 218.75 \text{ V}$$

At this time, the starting resistor R_3 will be taken out leaving only R_A in the circuit. The motor's current at that moment will increase to

$$I_{A,3} = \frac{V_T - E_{A,3}}{R_A} = \frac{250 - 218.75}{0.05} = 625 \text{ A}$$

which is less than the allowed value. Therefore, the resistances are

$$R_3 = R_{tot,3} - R_A = 0.0893 - 0.05 = 0.0393 \Omega$$

$$R_2 = R_{tot,2} - R_3 - R_A = 0.1786 - 0.0393 - 0.05 = 0.0893 \Omega$$

$$R_1 = R_{tot,1} - R_2 - R_3 - R_A = 0.357 - 0.1786 - 0.0393 - 0.05 = 0.1786 \Omega$$

The resistors R_1 , R_2 , and R_3 are cut out when E_A reaches 125 V, 187.5 V, and 218.75 V, respectively.



DC motor starting circuits

Several different schemes can be used to short contacts and cut out the sections of a starting resistor. Some devices commonly used in motor-control circuits are

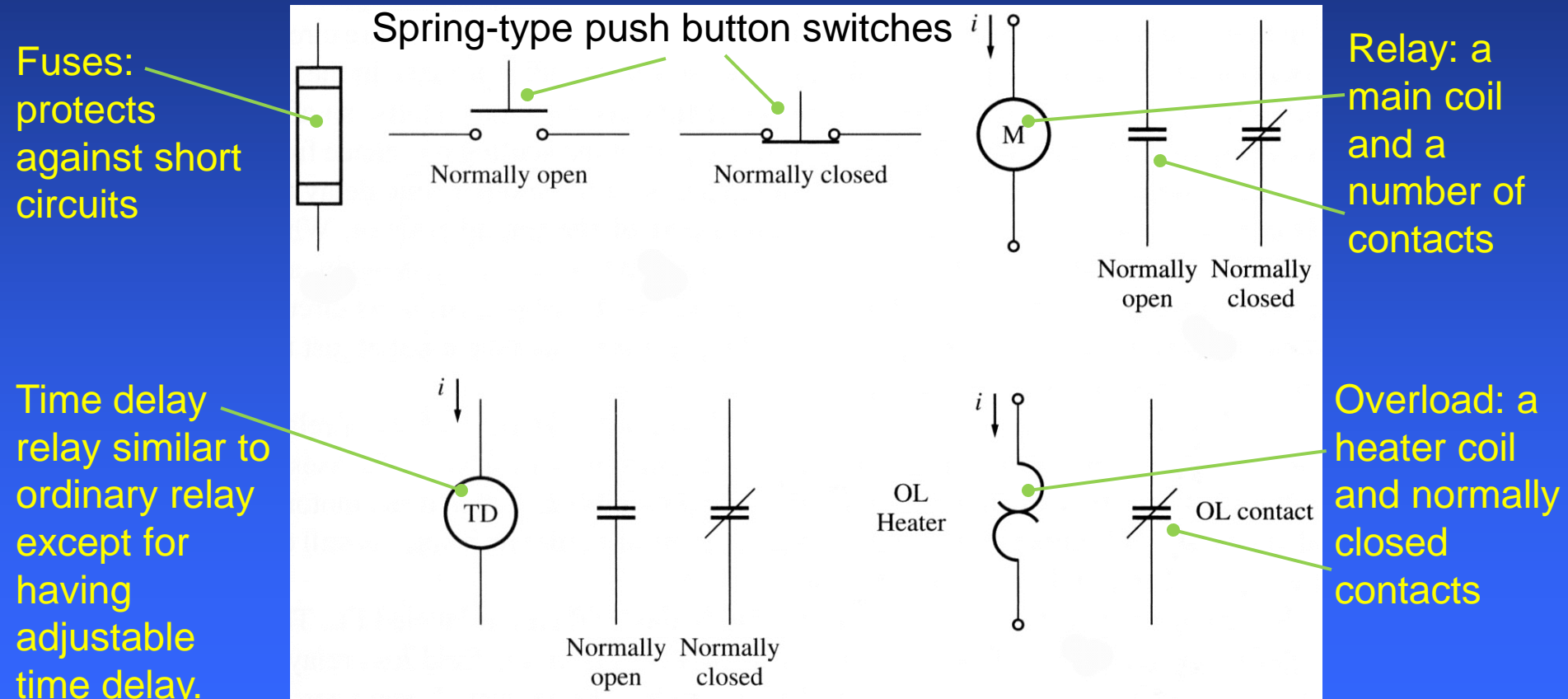

DC motor starting circuits

A common DC motor starting circuit:

A series of time delay relays shut contacts removing each section of the starting resistor at approximately correct times.

Notice that the relay 1TD is energized at the same time as the motor starts – contacts of 1TD will shut a part of the starting resistor after some time. At the same instance, relay 2TD is energized and so on...

Observe also 4 fuses protecting different parts of the circuit and the overload in series with the armature winding.

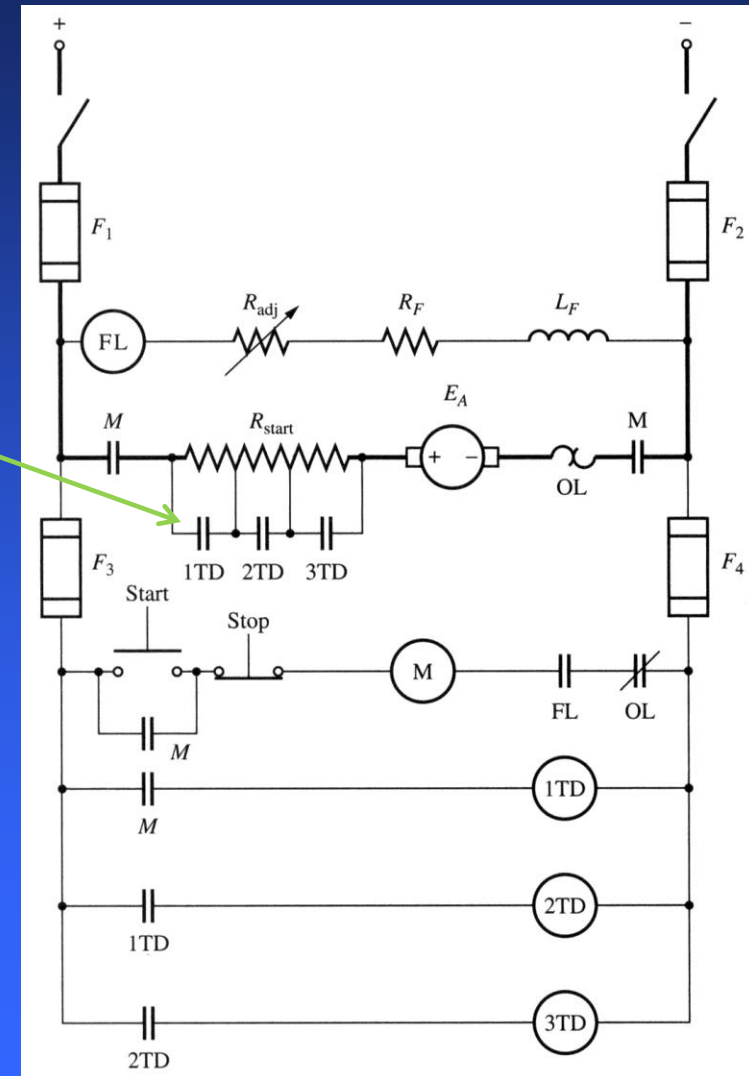

DC motor starting circuits

Another type of motor starter:

A series of relays sense the value of armature voltage E_A and cut out the starting resistors as it reaches certain values.

This starter type is more robust to different loads.

FL is the *field loss relay*: if the field is lost for any reason, power to the M relay will be turned off.

Armature current in a DC motor during starting.

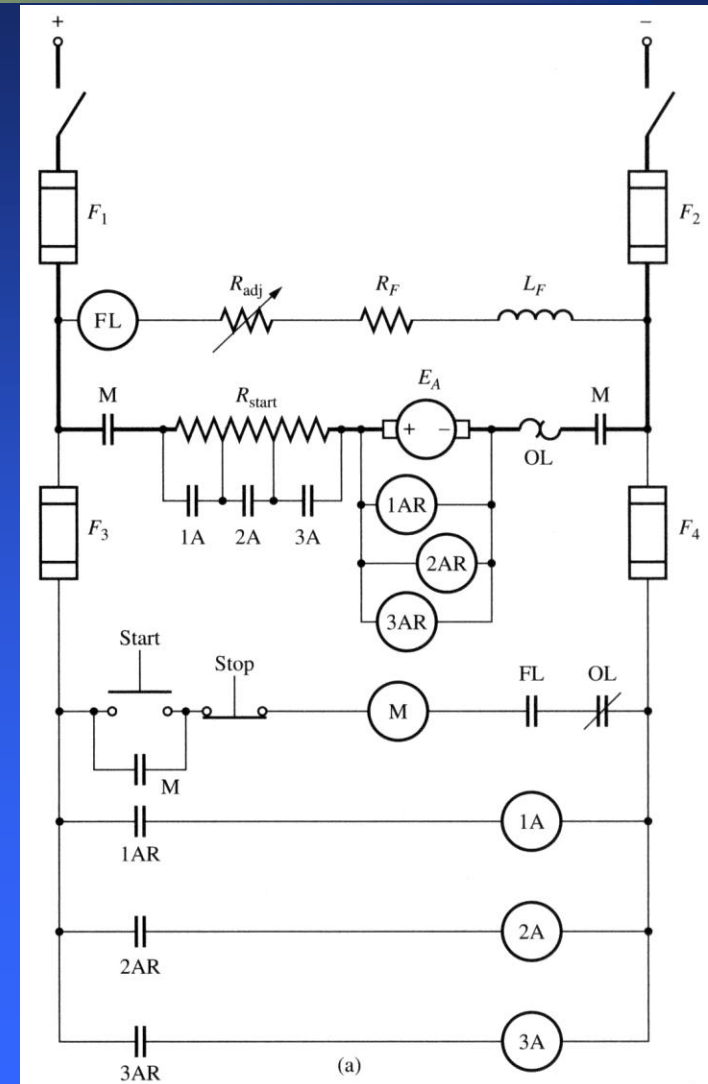
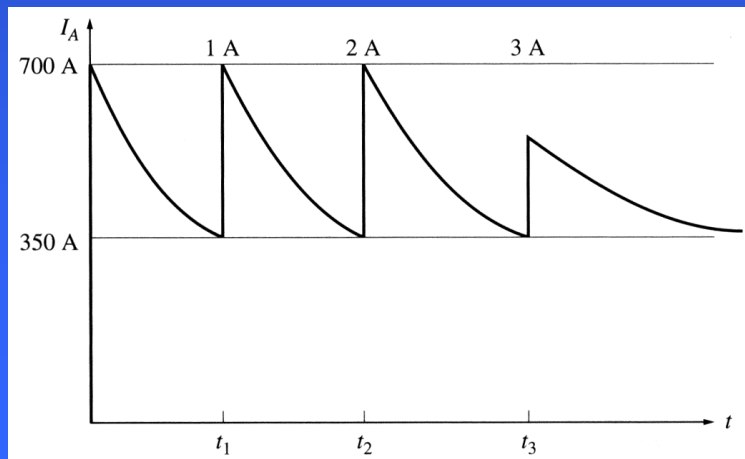

DC motor efficiency calculations

To estimate the efficiency of a DC motor, the following losses must be determined:

1. Copper losses;
2. Brush drop losses;
3. Mechanical losses;
4. Core losses;
5. Stray losses.

To find the copper losses, we need to know the currents in the motor and two resistances. In practice, the armature resistance can be found by blocking the rotor and a small DC voltage to the armature terminals: such that the armature current will equal to its rated value. The ratio of the applied voltage to the armature current is approximately R_A .

The field resistance is determined by supplying the full-rated field voltage to the field circuit and measuring the resulting field current. The field voltage to field current ratio equals to the field resistance.



DC motor efficiency calculations

Brush drop losses are frequently lumped together with copper losses. If treated separately, brush drop losses are a product of the brush voltage drop V_{BD} and the armature current I_A .

The core and mechanical losses are usually determined together. If a motor is running freely at no load and at the rated speed, the current I_A is very small and the armature copper losses are negligible. Therefore, if the field copper losses are subtracted from the input power of the motor, the remainder will be the mechanical and core losses. These two losses are also called the no-load rotational losses. As long as the motor's speed remains approximately the same, the no-load rotational losses are a good estimate of mechanical and core losses in the machine under load.

